

# Low-rise External Wall System

VERTICAL  
DESIGN AND  
INSTALLATION  
GUIDE

SUPER<sup>50</sup> & SUPER<sup>75LD</sup>

EDITION: NOVEMBER 2024



**NASAHI**<sup>®</sup>  
building smarter





---

# Contents

ABOUT NASAHI®	5
AUTOCLAVED AERATED CONCRETE (AAC)	6
ADVANTAGES OF NASAHI®	7
DESIGN PROCESS	8
DESIGN PRINCIPLES	9
DESIGN DETAIL CONSIDERATIONS	10
Wall Panel Layout	10
Penetrations	10
Footings	10
Termites	10
Control Joints	12
EXTERNAL COATINGS	14
Surface Preparation	14
Recommended Coating System	15
Type A and B Non-combustible Construction	15
STRUCTURAL PERFORMANCE	16
IMPACT RESISTANCE	22
FIRE RESISTANCE	23
ENERGY EFFICIENCY	25
CONDENSATION MANAGEMENT	30
ACOUSTIC PERFORMANCE	31
WEATHERPROOFING	32
ENVIRONMENTAL	33
EXTERNAL WALL SYSTEM OVERVIEW	34
EXTERNAL WALL SYSTEM COMPONENTS	35
EXTERNAL WALL SYSTEM INSTALLATION SEQUENCE	37
NCC COMPLIANCE	39
WORKING WITH NASAHI® PANELS	40
APPENDIX	40
Material Properties	40
Panel Reinforcement Layout	41
Detailed Drawings	42
BOUNDARY WALL DESIGN AND INSTALLATION	57
BASE SEALER	71
DELIVERY AND HANDLING	74
HEALTH AND SAFETY	75
GUARANTEE	76





---

# About Nasahi®

FOR THE PAST 20 YEARS NASAHI® HAVE BEEN ONE OF THE WORLD'S LARGEST PRODUCERS OF INNOVATIVE, HIGH QUALITY AAC MATERIALS.

We have become a world leader in the production of revolutionary building materials by investing over AU\$60 million in the most technologically advanced processes in the industry. Our production facility has the capacity of 700,000 m<sup>3</sup> of AAC products per year, selling within China and exporting to Japan, Singapore, Malaysia, Vietnam, Philippines, UAE, Maldives, Russia, Angola, Australia, New Zealand etc. Our reputation for consistently producing high quality products is exceptional.

The Nasahi® range of building systems are regularly tested in Australia by NATA accredited laboratories. They are carefully engineered to comply with the requirements of the Building Code of Australia, and to remain at the cutting edge of product innovation.

Nasahi's in-house engineers provide project specific guidance, assisting with custom projects and bringing your ideas to life.

With warehouses located in every state of Australia, Nasahi® can easily meet demands and quickly deliver to site.

Our ISO 9001 and JIS A 5416 manufacturing processes are audited annually by independent authorities. This ensures that we meet the needs of our customers and other stakeholders while complying with statutory and regulatory requirements.

By *Building Smarter* we provide a guarantee you can trust.

# Autoclaved Aerated Concrete (AAC)

AUTOCLAVED AERATED CONCRETE IS A LIGHTWEIGHT PRE-CAST CONCRETE BUILDING MATERIAL THAT PROVIDES EXCELLENT STRUCTURAL, THERMAL, FIRE, TERMITE AND MOULD-RESISTANCE.

AAC is manufactured from cement, sand, lime and water; it is aerated by adding an expanding agent to the mix. The mix is poured into a large mould and allowed to rise. These large soft blocks are sliced into the required panel sizes and are then cured in a steam pressure autoclave for up to 12 hours.

The result is a concrete panel filled with small, finely dispersed air bubbles, which is both strong and lightweight.

Embedded corrosion protected steel mesh inside the panels provide excellent strength when installed as external walls or over a load bearing timber or steel frame.

Nasahi® AAC panels comply with the Australian Standard for Reinforced Autoclaved Aerated Concrete for construction (AS 5146.2) with respect to the panels being used in wall applications.

Panels are supplied in a standard width of 600mm and a lengths as noted in Table 1 which can easily be cut to size allowing fast and strong installation.

Nasahi® Panels are designed to provide a superior wall cladding solution with the feel of concrete at a significantly reduced cost.

Excellent airborne noise transmission properties result in a quieter, more comfortable home for your family.

Manufactured from lightweight, reinforced, autoclaved aerated concrete, Nasahi® Panels are available in standard density and low density for panel thicknesses as outlined in this manual making them highly resistant to chipping and damage during delivery and handling.

Table 1 - Panel Weights

Panel Lengths (mm)	2400	2550	2700	2850	3000	3300
50mm Working Panel weight (590kg/m <sup>3</sup> at 12.4% moisture content)	43kg	46kg	48kg	51kg	53kg	N/A
75mm(LD) Working Panel weight (490kg/m <sup>3</sup> at 12.4% moisture content)	53kg	56kg	60kg	63kg	66kg	73kg

*Nasahi® AAC Panels can also be used for Flooring, Party Walls and Fences (see other Nasahi® Design Manuals for these applications.)*



---

# Advantages of Nasahi®

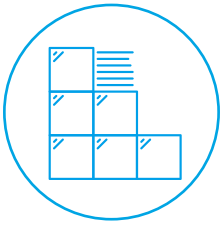

## QUICK INSTALLATION

Three qualified tradespeople can easily install 50-80m<sup>2</sup> of Nasahi® panels per day, making it significantly faster and less labour intensive than traditional masonry.



## TRANSPORTABLE

Panels packed on edge in packs of 15 for 50mm panels and 10 for 75mm panels, improving transportability to and around site.

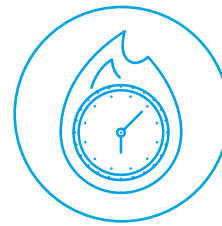

## FIRE RESISTANT

Nasahi® Panels are non-combustible and are compliant as external wall cladding in all Australian bushfire regions. Nasahi® Panels have been rigorously tested and will provide an FRL of up to 120/120/120 using standard 10mm plasterboard internal lining.

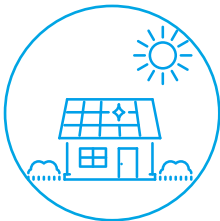

## THERMAL COMFORT

Nasahi® Systems achieve high thermal ratings and meet the NCC Energy Efficiency requirements for Australian Climate Zones.



## QUIET

The Nasahi® Panel's unique aerated construction provides the thermal performance of a lightweight system while delivering excellent acoustic performance like a dense masonry product.

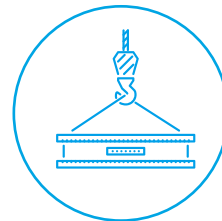

## LIGHTWEIGHT AND STRONG

Nasahi® Panels weigh less than standard concrete masonry, making it convenient, lightweight, and easy to work with. Strength is provided by corrosion protected internal steel reinforcing mesh.

---

# Design Process

THIS SECTION OUTLINES THE DESIGN PROCESS THAT SHOULD BE FOLLOWED WHEN DETERMINING THE NASAHI® EXTERNAL WALL SYSTEM DESIGN APPROPRIATE FOR YOUR PROJECT.

## STEP 1: SITE WIND LOADS

Determine the site wind load requirements including wind category, terrain category, topography and other factors that are required to calculate the site wind pressures acting on the cladding Page 17.

## STEP 2: OTHER REQUIREMENTS

In addition to wind loads, these will include weatherproofing & energy efficiency, and may also include fire resistance levels (FRL), bush-fire attack level (BAL) & sound insulation.

## STEP 3: SELECT CAVITY

Using Tables on Page 18-21 select the suitable cavity, cavity spacing and fixing required to meet the requirements outlined in step 1.

## STEP 4: ENERGY EFFICIENCY

Using Table 12 Page 27 for 50mm panel and 12.1 on Page 28 for 75mm panel, select the appropriate insulation and wall wrap material to meet the energy efficiency and weatherproofing requirements determined in Step 2.

## STEP 5: CALCULATE REQUIRED COMPONENTS

Determine the number of panels, metal battens (top hat) battens and fasteners required for the project.

## DURABILITY - COASTAL AREAS

Nasahi® Panels can be used in coastal areas; however care should be taken to maintain these walls and prevent salt build up over time. For buildings that are less than 1km from the coastline or other large bodies of salt water, the following guidelines are recommended:

- If walls cannot adequately self-clean during natural rain events, it is recommended that a regular wash-down of wall surfaces be performed to remove the risk of salt or dirt build up over time.
- Additionally a yearly inspection of all sealant joints should be conducted and where the sealant is found to be failing, remedial maintenance should be performed.
- Nasahi® panels can be installed in coastal areas using Class 3 screws however, the screw heads should be countersunk no less than 5mm into the panel external face and filled with Nasahi® adhesive. An approved Nasahi® Render coating system (including paint membrane) must be applied over the external face of these walls and maintained as per the guidelines above.



---

# Design Principles

THIS TECHNICAL GUIDE SPECIFIES DESIGN PRINCIPLES FOR THE NASAHI® EXTERNAL WALL PANEL SYSTEM THAT COMPLY WITH THE PERFORMANCE REQUIREMENTS OF THE NCC AT THE TIME OF WRITING. THE DESIGNER MUST CHECK THE ADEQUACY OF THE BUILDING SOLUTION FOR COMPLIANCE WITH THE APPROPRIATE AUTHORITY.

## A) LATERAL WIND LOADS

Lateral wind loads experienced by the panels are transferred through the panel fasteners, and into the load bearing stud frame, which must be designed in accordance with the relevant Australian Standards for the site loads determined earlier. The frame must be designed for all bracing and hold-down requirements.

## B) OPENINGS

Windows, door frames and penetrations must be sealed and a water resistant approved external coating must be applied to the external surface of the panel.

## C) BOUNDARY

For boundary wall applications, panels may be installed uncoated provided the wall is made weatherproof at the top and sides, and a drained cavity is present between adjoining boundary walls. Insulation batts must be 'strung' between studs to prevent contact with the inside face of the panel.

## CRITERIA FOR CORNER PANELS

Panels within a distance of 1200mm from building corners experience higher wind loads. Due to this increase of wind load, extra battens and screws may be necessary in each direction from the corner. Batten and fixing spacing requirements are shown in details on Pages 18-21.

## FRAMING DESIGN

The load bearing stud frame must be designed in accordance with NCC requirements for timber or steel frames, taking into account the permanent loads imposed by the panels as outlined in Table 5 on Page 16.

### TIMBER FRAMES

Timber framing must be designed in accordance with the relevant parts of AS1684. Stud spacing and height should be designed to suit the wind loadings and panel permanent loads in accordance with local codes. Noggins must be flush fitted at a maximum of 1350mm centre spacing.

Timber framing shall comply with clause C2D13 of the NCC 2022 if used in Type A or B construction.

### STEEL FRAMES

Steel framing must comply with NASH Standard 2021. For steel framing the minimum framing specification is 'C' section studs and noggins of overall section size 75mm web and 32mm flange. Minimum Steel thickness must be in accordance with AS3623 and AS/NZ4600.

### BRACING

Timber and steel framed walls must be braced for a medium weight wall cladding in accordance with AS1684 for timber framing and AS3623 and AS/NZS4600 for steel framing.

---

# Design Detail Considerations

## WALL PANEL LAYOUT

All care should be taken to work to panel widths, this will help minimise the number of panels required during construction, and reduce the likelihood of cutting through the embedded corrosion protected steel mesh. Steel reinforcing mesh layout can be seen in Details on Page 41.

## PENETRATIONS

Services should be run through the frame, not installed in the wall cavity. Where services penetrate through the wall, a 5-10mm gap should be created around the service. Gaps must be filled with backing rod and an appropriate flexible sealant (fire rated where specified). A fire rated penetration collar may be required around the service and penetration, check with the project engineer.

## FOOTINGS

All applications of the wall systems shall only be applied to buildings with footings and slabs in accordance with AS2870 (for Class 1&10 Buildings).

Panels can either be supported on an AS2870 compliant rebated slab edge, or hung from the load-bearing frame overhanging the concrete slab or timber base. Maximum overhang 250mm as shown in Detail 3.0 on Page 46. For bushfire rated applications, rebated slab installations are recommended and appropriate measures must be taken for control of burning embers as required by the NCC.

## TERMITES

Nasahi® Panels are resistant to termites, however, termite protection is a mandatory requirement to protect internal building components. Termite protection must be installed in accordance with local codes and NCC requirements taking into account state variations.





---

# Control Joints

Render cracking is caused by stresses due to various building materials expanding and contracting at different rates. Control Joints shall be a minimum of 10mm wide and shall consist of an expanded polystyrene tube or backing rod and a polyurethane multi-purpose external grade material gunned into the joints to form a 10mm wide x 5mm deep flexible seal.

Control joints shall incorporate de-bonding tape. For walls requiring resistance against fire, a fire rated sealant suitable for the degree of fire resistance shall be used. See Details 1.1 to 1.2 on Page 42.

Table 2 - Vertical Control Joint Locations

---

<b>VERTICAL</b>	
<b>SPACING OF ARTICULATED JOINTS IN HOUSES AND LOW-RISE MULTI-RESIDENTIAL BUILDINGS</b>	
<b>Site Class</b>	<b>Joint Spacing, m</b>
A,S	6.0
M,M-D	5.5
H1, H1-D	5.0
H2, H2-D	4.5

---

Note:

Site class as defined in AS 2870. For further information and guidance on site classification, refer to AS 2870.

Reference AS5146.3 Table 2.9.1

*Note: Prior to the application of the external coating system it is important and mandatory that all lock up construction and any associated works are thoroughly completed.*



## VERTICAL CONTROL JOINTS

The following outlines the positioning of Control Joints in the Nasahi® 50mm External Vertical Panel System.

1. Control joints must not be spaced further than noted in Table 2 for site classification
2. Vertical control Joints are required at external and internal corners.
3. If external corners are meshed then an external corner control joint can be moved up to 1.2m from external corner and or to the closest opening to the corner if it is less than 1.2m from the corner.
4. Vertical CJ's are required above and below all door openings of any kind.
5. A vertical control Joint is required at a location where there is a change in building height of greater than 20%.
6. In two storey construction vertical control joints in upper and lower walls are not required to be aligned but must be terminated at the horizontal control Joint.
7. A horizontal control Joint is required at all floor junctions.
8. Max distance between Horizontal control Joint is to be no greater than 3600mm.

## WINDOW OPENINGS

1. For opening less than or equal to 2400 no control Joint is required, provided the maximum spacing between control Joint's is not exceeded and if there is at least 600mm above and below the opening or if the Joint is meshed in the render.
2. For openings greater than 2400mm and up to 3600mm in width at least one control Joint is required at opening. The opposite panel joint at opening which is not a control Joint must be glued and meshed in the render.
3. For opening greater than 3600mm both sides of opening must be a control Joint.
4. Panels abutting the opening should be positioned with a 2-3mm gap between the window frame and panel allowing the control Joint to be installed above and below the opening only.
5. A gap of 2-3mm should also be adopted on horizontal jambs above and below the window.
6. If the horizontal lintel panel above the window is fully meshed in the render it may be a minimum of 150mm in height otherwise a height of 270mm must be maintained.

Table 2.1 - Horizontal Control Joint Locations

---

### HORIZONTAL

---

A 10mm horizontal control joint (see Detail 5.0 on Page 50) is required at each FLOOR JOIST ZONE

\*Less than 1% shrinkage of the floor joist depth as confirmed by the design engineer

---

 Reference AS5146.3 Clause 2.9.2

# External Coatings

## EXTERNAL COATINGS

The selected external coating must provide weatherproofing and durability. Nasahi® approves coating systems that achieve the performance levels outlined in Table 3 below and Table 4 on Page 15 and Clause 2.8.4 of AS 5146.3. Nasahi® have provided an example of a coating system below that achieves compliance with these requirements. It is the responsibility of the building designer to select a suitable system, and for the installer to ensure these specifications are met, complete an Installation Compliance Certificate, and submit copies to both the builder and Nasahi®.

Table 3 - Coating Performance Level

TEST	PERFORMANCE REQUIREMENT	UNIT
Water Transmission Resistance	< 10	g/m <sup>2</sup> /24hr/1kPa
Water Vapour Permeability	w. sd ≤ 0.2	kg/(m <sup>2</sup> .h <sup>0.5</sup> )
Co-efficient of Water Absorption	w ≤ 0.5	kg/(m <sup>2</sup> .h <sup>0.5</sup> )
Equivalent Air Layer Thickness of Water Vapour Diffusion	sd ≤ 2	m
Durability	Minimum 7-year warranty	-
Elasticity	Bridge a minimum crack width of 1mm	-

Note: A co-efficient of water absorption ( $w \leq 0.5$ ) means that minimal water is absorbed regardless of time period. A Coating with  $Sd \geq 2m$  has less resistance to water vapour diffusion (escape) than a static 2m thick layer of air.

## SURFACE PREPARATION

Before applying the coating system, the applicator must hose down the panels with fresh potable water, ensure that all required penetrations and fire collars have been correctly installed and Nasahi® Panels are dry after hosing down and clean of debris/oil. Surface protrusions must be trimmed back, and large imperfections filled with Nasahi® Panel Adhesive. Exposed reinforcing bars must be coated with Nasahi® Corrosion Protection Touch up Paint. AAC substrate shall be allowed to reach equilibrium moisture content prior to application of coating.

*Note: Prior to the application of the external coating system it is important and mandatory that all lock up construction and any associated works are thoroughly completed.*

## RECOMMENDED COATING SYSTEM

Nasahi® recommends the following system be used on External Walls as it has been shown to meet the approved coating specification.

Table 4 - Recommended Coating System

APPLICATION TO	RECOMMENDATION
External Corner Angles	32mm x 32mm Aluminium, PVC or Stainless-Steel corner angles.
Primer Coat (to manufacturer specifications)	Primer/Sealer to enhance adhesion (if required by coating manufacturer)
Base Coat Render*	High build acrylic, Portland cement-based render with thickness of 2-6mm. This base coat must encapsulate the reinforcing mesh.
Reinforcing Mesh*	165g/m <sup>2</sup> Alkali resistant fiberglass mesh with minimum aperture 5mm square embedded into the base coat render.
Texture Coat*	Cement based polymer modified dry powder or wet pre-mixed full acrylic texture coating with minimum thickness 1mm applied with trowel or float over base coat.
Paint System	A minimum of two coats of 100% acrylic-based exterior paint should be applied to a thickness of 150um per coat, and have crack bridging capability of 5 times the total dry film thickness. Note: Must be used in marine exposure environments as per AS4654.1.

\* These components of the coating system are required as per AS5146.3.

## TYPE A AND B NON-COMBUSTIBLE CONSTRUCTION

As per Clause C2D10(4)(o) of the NCC 2022, the above external coating system is suitable to be used in Type A and B non-combustible construction and the Nasahi® wall system arrangement complies with the Performance Requirement C1P1 and C1P2 of the NCC.

Only Aluminium or Stainless Steel corner angles (and not PVC corner angles) may be used in Type A or B construction.

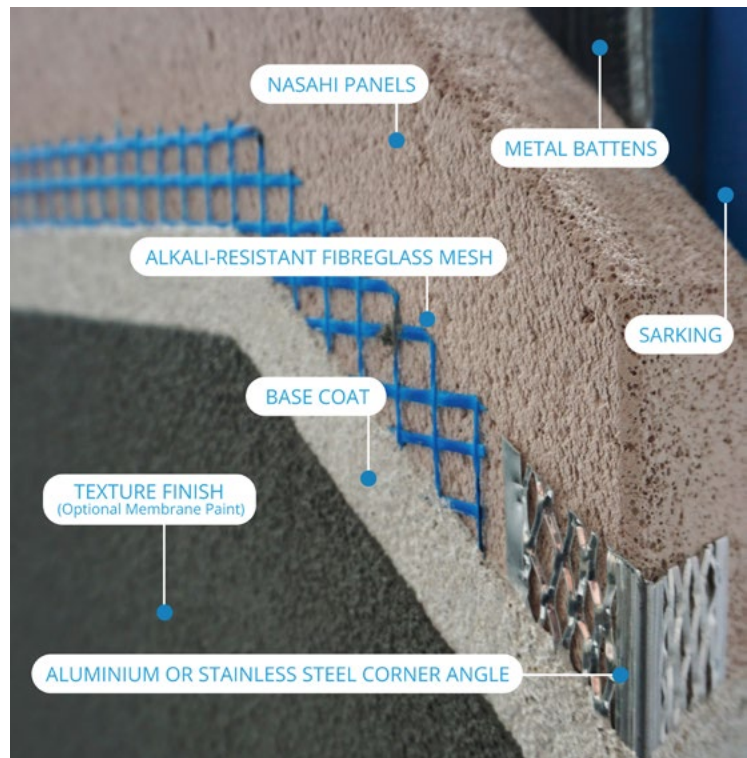

*Note: Prior to the application of the external coating system it is important and mandatory that all lock up construction and any associated works are thoroughly completed.*

# Structural Performance

THE NASAHI® EXTERNAL WALL SYSTEM IS A NON LOAD-BEARING SYSTEM THAT IS DESIGNED TO BE INSTALLED ONTO A LOAD BEARING TIMBER OR STEEL FRAME.

## PANEL WEIGHT

For single storey panel on slab installations, the panel weight is supported by the slab and no additional frame design is required.

For two storey construction the upper panels may be suspended from the frame (this is typical if there are openings below the upper

panels) If this is the case then the upper panels will impose an additional load on the lower frame. The designer must allow for the extra load that the upper panels and coatings will imposed on the lower frame as noted in Table 5.

Table 5 - Super<sup>50</sup> Panel Loads

PANEL LENGTH (mm)	2400	2550	2700	2850	3000
Panel Weight (kg)	42.5	45.1	47.8	50.4	53.1
Panel Weight /m width (kg)	70.8	75.2	79.7	84.1	88.5
Design Dead Load/m width (KN/m)	0.695	0.738	0.781	0.825	0.868

Super<sup>75LD</sup> Panel Loads

PANEL LENGTH (mm)	2400	2550	2700	2850	3000	3300
Panel Weight (kg)	52.9	56.2	59.5	62.8	66.2	72.8
Panel Weight /m width (kg)	88.2	93.7	99.2	110.4	110.3	121.3
Design Dead Load/m width (KN/m)	0.865	0.919	0.973	1.027	1.082	1.190

Note: Weights are based on Design Moisture Content of 12.4%

50mm = 590kg/m<sup>3</sup>

75mm = 490kg/m<sup>3</sup>



# Wind Zone

NASAHI® SUPER<sup>50</sup> & SUPER<sup>75LD</sup> AAC CLADDING PERMANENT ACTIONS AND WIND ACTIONS HAVE BEEN CONSIDERED FOR THE ENCLOSED FIXING GUIDE AND SPAN TABLES.

AAC working density as detailed in Appendix - Table 17 - Material Properties on Page 40 and other material self-weight has been used to determine the permanent actions "G" as defined in AS/NZS 1170.0.

## WIND ACTION

Non-cyclonic wind regions N1, N2, N3, N4, N5 & N6 plus Cyclonic wind regions C1 and C2 as defined in AS/NZS 1170.2 and AS 4055 have been used in the enclosed fixing guide and span table development.

The following table is extracted from AS 4055:2021 to demonstrate the wind loads modelled.

Table 6 - Wind Loads

AS4055 WIND ZONES (WALLS)	GENERAL AREAS/ANY POSITION ULS WIND PRESSURE (KPA)	AWAY FROM CORNERS ULS WIND PRESSURE (KPA)	WITHIN 1,200MM OF CORNERS ULS WIND PRESSURE (KPA)
N1w	+0.62	-0.53	-0.94
N2w	+0.86	-0.74	-1.30
N3w	+1.35	-1.16	-2.03
N4w	+2.01	-1.72	-3.01
N5w	+2.96	-2.53	-4.44
N6w	+3.99	-3.42	-5.99
C1w	+1.8	-1.80	-2.70
C2w	+2.68	-2.68	-4.02

It should be noted that AS 5146.2 refers to wind loadings as detailed in AS 4055:2012 which has been superseded. The calculated wind loads in the current version AS 4055:2021 have been modified and, in some cases increased compared to the previous version. This report relies on AS 4055:2021 which is current at the time of publication.

Please also note, Cyclonic wind regions C3 & C4 require specific wall system detailing and fastener selection, wind regions C3 & C4 are excluded from the scope of this report.

## LOAD CONDITIONS

As required by AS/NZS 1170.0, the following load combinations have been applied:

Where:

$$1.35 \times G$$

$$1.2 \times G + W_u$$

$G = 360 \text{ N/m}^2$  for the Nasahi® 50mm AAC panel in accordance with AS 5146.2:2018

Reference Clarkson Consulting services Report No: NAS\_23Span01\_v1.1 Dated 20 October 2023

## BATTEN & SCREW TABLES - 50MM PANELS

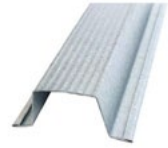

Table-7.0 - No. of Metal Battens (Top Hat) - External Fixing of Panels

TABLE 7.0 - NO. OF METAL BATTENS (TOP HAT) - EXTERNAL FIXING OF PANELS					SUPER <sup>50</sup> PANELS							
VERTICALLY ORIENTED PANELS - BASE SUPPORTED AND OR SUSPENDED FROM FRAME (MIN 0.48 BMT)												
AS4055 WIND ZONES	GENERAL AREAS ULS WIND PRESSURE (kPA)	CORNER ZONES ULS WIND PRESSURE (kPA)	RECOMMENDED STUD SPACING (MM)		NO. OF TOP HATS REQUIRED							
					PANEL LENGTHS (MM)							
			GEN	CNR	2400		2700		2850		3000	
N1w	-0.53	-0.94	600	600	3	3	3	3	3	3	3	3
N2w	-0.74	-1.30	600	600	3	3	3	4	3	4	3	4
N3w	-1.16	-2.03	600	600	3	4	3	5	4	5	4	5
			450	450	3	4	3	4	4	4	4	5
N4w	-1.72	-3.01	450	450	4	4	4	5	4	5	4	5
N5w	-2.53	-4.44	450	300	4	5	4	5	5	6	5	6
N6w	-3.42	-5.99	450	300	4	5	5	6	5	6	5	6
C1w	-1.80	-2.70	450	450	4	4	4	5	4	5	4	5
C2w	-2.68	-4.02	450	400	4	5	4	5	5	6	5	6

Table 7.1 - No. of Screws - External Fixing of Panels

TABLE 7.1 - NO. OF SCREWS - EXTERNAL FIXING OF PANELS					SUPER <sup>50</sup> PANELS							
AS4055 WIND ZONES	GENERAL AREAS ULS WIND PRESSURE (kPA)	CORNER ZONES ULS WIND PRESSURE (kPA)	RECOMMENDED STUD SPACING (MM)		SCREWS PER TOP HAT / PANEL							
					PANEL LENGTHS (MM)							
			GEN	CNR	2400		2700		2850		3000	
N1w	-0.53	-0.94	600	600	2	2	2	2	2	2	2	2
N2w	-0.74	-1.30	600	600	2	2	2	2	2	2	2	2
N3w	-1.16	-2.03	600	600	2	2	2	2	2	2	2	2
			450	450	2	2	2	2	2	2	2	2
N4w	-1.72	-3.01	450	450	2	3	2	2	2	3	2	3
N5w	-2.53	-4.44	450	300	2	3	3	3	2	3	2	3
N6w	-3.42	-5.99	450	300	3	4	3	4	3	4	3	4
C1w	-1.80	-2.70	450	450	2	2	2	2	2	2	2	2
C2w	-2.68	-4.02	450	400	2	3	3	3	2	3	2	3

Table 7.2 - No. of Metal Battens (Top Hat) - Internal Fixing of Panels

TABLE 7.2 - NO. OF METAL BATTENS (TOP HAT) - INTERNAL FIXING OF PANELS					SUPER <sup>50</sup> PANELS							
VERTICALLY ORIENTED PANELS - BASE SUPPORTED ONLY (MIN 0.48 BMT)												
AS4055 WIND ZONES	GENERAL AREAS ULS WIND PRESSURE (kPA)	CORNER ZONES ULS WIND PRESSURE (kPA)	RECOMMENDED STUD SPACING (MM)		NO. OF TOP HATS REQUIRED							
					PANEL LENGTHS (MM)							
			GEN	CNR	2400		2700		2850		3000	
N1w	-0.53	-0.94	600	600	3	3	3	3	3	3	3	3
N2w	-0.74	-1.30	600	600	3	3	3	4	3	4	3	4
N3w	-1.16	-2.03	450	450	3	4	3	4	4	4	4	5
N4w	-1.72	-3.01	450	450	4	4	4	5	4	5	4	5
*N5w	-2.53	-4.44	450	300	4	5	4	5	5	6	5	6
*N6w	-3.42	-5.99	450	300	4	5	5	6	5	6	5	6
C1w	-1.8	-2.7	450	450	4	4	4	5	4	5	4	5
C2w	-2.68	-4.02	450	400	4	5	4	5	5	6	5	6

\* Consideration should be given to above highlighted orange, plus N5w & N6w due to the excessive quantity of top hats and fasteners required.

Reference Document: Clarkson Consulting services Report No:NAS\_24Span\_50\_v2.1 Dated 21 November 2024

## BATTEN & SCREW TABLES - 50MM PANELS

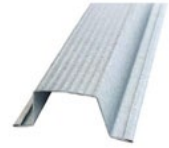

Table 7.3 - No. of Screws - Internal Fixing of Panels

TABLE 7.3 - NO. OF SCREWS - INTERNAL FIXING OF PANELS					SUPER <sup>50</sup> PANELS							
AS4055 WIND ZONES	GENERAL AREAS ULS WIND PRESSURE (kPA)	CORNER ZONES ULS WIND PRESSURE (kPA)	RECOMMENDED STUD SPACING (MM)		SCREWS PER TOP HAT / PANEL							
					PANEL LENGTHS (MM)							
			GEN	CNR	2400		2700		2850		3000	
					GEN	CNR	GEN	CNR	GEN	CNR	GEN	CNR
N1w	-0.53	-0.94	600	600	2	3	2	3	2	3	2	3
N2w	-0.74	-1.30	600	600	2	4	2	3	3	3	3	3
N3w	-1.16	-2.03	450	450	3	4	4	5	3	5	3	4
N4w	-1.72	-3.01	450	450	4	6	4	5	4	6	4	6
*N5w	-2.53	-4.44	450	300	5	7	6	8	5	7	5	7
*N6w	-3.42	-5.99	450	300	7	9	6	9	6	9	7	9
C1w	-1.8	-2.7	450	450	4	5	4	5	4	5	5	5
C2w	-2.68	-4.02	450	400	5	6	6	7	5	6	5	7

\* Consideration should be given to above highlighted orange, plus N5w & N6w due to the excessive quantity of top hats and fasteners required.

### Notes:

1. Negative pressure indicates wind suction
2. Assumed Nasahi® 50mm Panel Dry Density of 525 kg/m<sup>3</sup> and working density of 590 kg/m<sup>3</sup>
3. All top hats to be spaced evenly, with top and bottom top hats installed 100-250mm from the ends of the Nasahi® 50mm AAC Panel
4. Corner panel location applies to all wall cladding and fasteners within 1,200mm of external building corners
5. Where Nasahi® 50mm AAC Panels are cantilevered greater than 250mm, cantilevers may extend no more than 450mm, 1 additional top hat shall be installed behind the cantilevered panels to share load across panels
6. A minimum of 2 screws per top hat (per panel) for external fixing
7. minimum of 3 screws per top hat (per panel) for internal fixing (Unless Noted Otherwise)
8. Top Hats shall be secured to Studs using 2 x TEK Screws at each Stud, using the following screws:
  - a. For Timber Studs 12-11 x 35mm Hex Head Type 17 Class 3 screws
  - b. For Steel Studs 10-16 x 20mm Hex Head Self-drilling Class 3 screws
9. Rondo 311D & 314 Direct fix clips to be used where walls are not exposed to external wind loads (dual zero-boundary walls, intertenancy walls etc)
10. Dual Zero Boundary Walls, 1st wall constructed only assumed to be exposed to temporary Wind Loads (refer relevant tables if wind loads exceed those nominated)
11. Panel Screws for External Fixing to Steel Top Hats – 14-10x65mm Bugle Head Type 17 or Hex Head Self-Drilling Class 3 screws
12. Panel Screws for Internal Fixing through Steel Top Hats into AAC – 12-11x45mm Hex Head Type 17 Class 3 screws (Care to be taken to NOT over torque screws)
13. Top Hat battens must be no less than 0.48mm BMT. For BMT less than 0.48mm contact Nasahi® Technical

📄 Reference Document: Clarkson Consulting services Report No:NAS\_24Span\_50\_v2.1 Dated 21 November 2024

*Note: Consideration should be given to above highlighted orange, plus N5w & N6w due to the excessive quantity of top hats and fasteners required*

## BATTEN & SCREW TABLES - 75MM PANELS

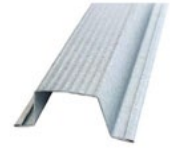

Table-7.4 - No. of Metal Battens (Top Hat) - External Fixing of Panels

TABLE 7.4 - NO. OF METAL BATTENS (TOP HAT) - EXTERNAL FIXING OF PANELS					SUPER <sup>75LD</sup> PANELS									
VERTICALLY ORIENTED PANELS - BASE SUPPORTED AND OR SUSPENDED FROM FRAME (MIN 0.48 BMT)														
AS4055 WIND ZONES	GENERAL AREAS ULS WIND PRESSURE (kPA)	CORNER ZONES ULS WIND PRESSURE (kPA)	RECOMMENDED STUD SPACING (MM)		NO. OF TOP HATS REQUIRED									
					PANEL LENGTHS (MM)									
					2400		2700		2850		3000		3300	
			GEN	CNR	GEN	CNR	GEN	CNR	GEN	CNR	GEN	CNR	GEN	CNR
N1w	-0.53	-0.94	600	600	3	3	3	3	3	3	3	4	3	4
N2w	-0.74	-1.30	600	600	3	4	3	4	3	4	3	4	4	4
N3w	-1.16	-2.03	600	600	3	4	4	5	4	5	4	5	4	6
			450	450	3	4	3	4	4	4	4	5	4	5
N4w	-1.72	-3.01	450	400	4	5	4	6	4	6	4	6	5	6
N5w	-2.53	-4.44	450	300	4	5	4	5	5	6	5	6	5	6
N6w	-3.42	-5.99	400	300	4	5	5	6	5	6	5	6	6	7
C1w	-1.80	-2.70	450	400	4	5	4	5	4	5	4	6	5	6
C2w	-2.68	-4.02	400	300	4	5	4	5	5	6	5	6	5	6

Table 7.5 - No. of Screws - External Fixing of Panels

TABLE 7.5 - NO. OF SCREWS - EXTERNAL FIXING OF PANELS					SUPER <sup>75LD</sup> PANELS									
VERTICALLY ORIENTED PANELS - BASE SUPPORTED AND OR SUSPENDED FROM FRAME (MIN 0.48 BMT)														
AS4055 WIND ZONES	GENERAL AREAS ULS WIND PRESSURE (kPA)	CORNER ZONES ULS WIND PRESSURE (kPA)	RECOMMENDED STUD SPACING (MM)		SCREWS PER TOP HAT / PANEL									
					PANEL LENGTHS (MM)									
					2400		2700		2850		3000		3300	
			GEN	CNR	GEN	CNR	GEN	CNR	GEN	CNR	GEN	CNR	GEN	CNR
N1w	-0.53	-0.94	600	600	2	2	2	2	2	2	2	2	2	2
N2w	-0.74	-1.30	600	600	2	2	2	2	2	2	2	2	2	2
N3w	-1.16	-2.03	600	600	2	2	2	2	2	2	2	2	2	2
			450	450	2	2	2	2	2	2	2	2	2	2
N4w	-1.72	-3.01	450	400	2	2	2	2	2	2	2	2	2	2
N5w	-2.53	-4.44	450	300	2	3	3	3	2	3	2	3	3	3
N6w	-3.42	-5.99	400	300	3	4	3	4	3	4	3	4	3	4
C1w	-1.80	-2.70	450	400	2	2	2	2	2	2	2	2	2	2
C2w	-2.68	-4.02	400	300	2	3	3	3	2	3	2	3	3	3

Table 7.6 - No. of Metal Battens (Top Hat) - Internal Fixing of Panels

TABLE 7.6 - NO. OF METAL BATTENS (TOP HAT) - INTERNAL FIXING OF PANELS					SUPER <sup>75LD</sup> PANELS									
VERTICALLY ORIENTED PANELS - BASE SUPPORTED ONLY (MIN 0.48 BMT)														
AS4055 WIND ZONES	GENERAL AREAS ULS WIND PRESSURE (kPA)	CORNER ZONES ULS WIND PRESSURE (kPA)	RECOMMENDED STUD SPACING (MM)		NO. OF TOP HATS REQUIRED									
					PANEL LENGTHS (MM)									
					2400		2700		2850		3000		3300	
			GEN	CNR	GEN	CNR	GEN	CNR	GEN	CNR	GEN	CNR	GEN	CNR
N1w	-0.53	-0.94	600	600	3	3	3	3	3	3	3	4	3	4
N2w	-0.74	-1.30	600	450	3	4	3	4	3	4	3	4	4	4
N3w	-1.16	-2.03	450	450	3	4	3	4	4	4	4	5	4	5
N4w	-1.72	-3.01	450	300	4	5	4	6	4	6	4	6	5	6
*N5w	-2.53	-4.44	400	300	4	5	4	5	5	6	5	6	5	6
*N6w	-3.42	-5.99	300	300	4	5	5	6	5	6	5	6	6	7
C1w	-1.80	-2.70	450	300	4	5	4	5	4	5	4	6	5	6
C2w	-2.68	-4.02	400	300	4	5	4	5	5	6	5	6	5	6

\* Consideration should be given to above highlighted Orange cells, plus N5w & N6w due to the excessive quantity of Top Hats and fasteners required.

Reference Document: Clarkson Consulting services Report No:NAS\_24Span\_75\_v1.1 Dated 21 November 2024



## BATTEN & SCREW TABLES - 75MM PANELS

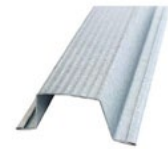

Table 7.7 - No. of Screws - Internal Fixing of Panels

TABLE 7.7 - NO. OF SCREWS - INTERNAL FIXING OF PANELS					SUPER <sup>75LD</sup> PANELS									
AS4055 WIND ZONES	GENERAL AREAS ULS WIND PRESSURE (kPA)	CORNER ZONES ULS WIND PRESSURE (kPA)	RECOMMENDED STUD SPACING (MM)		SCREWS PER TOP HAT / PANEL									
					PANEL LENGTHS (MM)									
			GEN	CNR	2400		2700		2850		3000		3300	
N1w	-0.53	-0.94	600	600	2	3	2	3	2	3	2	3	2	3
N2w	-0.74	-1.30	600	450	2	3	2	3	3	3	3	3	2	4
N3w	-1.16	-2.03	450	450	3	4	4	5	3	5	3	4	3	5
N4w	-1.72	-3.01	450	300	4	5	4	5	4	5	4	5	4	5
*N5w	-2.53	-4.44	400	300	5	7	6	8	5	7	5	7	6	8
*N6w	-3.42	-5.99	300	300	7	9	6	9	6	9	7	9	6	9
C1w	-1.80	-2.70	450	300	4	4	4	5	4	5	5	5	4	5
C2w	-2.68	-4.02	400	300	5	6	6	7	5	6	5	7	6	7

\* Consideration should be given to above highlighted Orange cells, plus N5w & N6w due to the excessive quantity of Top Hats and fasteners required.

### Notes:

1. Negative pressure indicates wind suction
2. Assumed Nasahi<sup>®</sup> 75mm (LD) Panel Dry Density of 435 kg/m<sup>3</sup> and working density of 490 kg/m<sup>3</sup>
3. All top hats to be spaced evenly, with top and bottom top hats installed 100-250mm from the ends of the Nasahi<sup>®</sup> 75mm (LD) AAC Panel
4. Corner panel location applies to all wall cladding and fasteners within 1,200mm of external
5. Where Nasahi<sup>®</sup> 75mm (LD) AAC Panels are cantilevered greater than 250mm, cantilevers may extend no more than 450mm, 1 additional top hat shall be installed behind the cantilevered panels to share load across panels
6. A minimum of 2 screws per top hat (per panel) for external fixing
7. A minimum of 3 screws per top hat (per panel) for internal fixing (Unless Noted Otherwise)
8. Top Hats shall be secured to Studs using 2 x TEK Screws at each Stud, using the following screws
  - a). For Timber Studs 12-11 x 35mm Hex Head Type 17 Class 3 screws
  - b). For Steel Studs 10-16 x 20mm Hex Head Self-drilling Class 3 screws
9. Rondo 311D & 314 Direct fix clips to be used where walls are not exposed to external wind loads (dual zero-boundary walls, intertenancy walls etc)
10. Dual Zero Boundary Walls, 1st wall constructed only assumed to be exposed to temporary Wind Loads (refer relevant tables if wind loads exceed those nominated)
11. Panel Screws for External Fixing 75mm AAC to Steel Top Hats – 14-10x95mm Bugle Head Type 17 or Hex Head Self-Drilling Class 3 screws
12. Panel Screws for Internal Fixing through Steel Top Hats into 75mm AAC – 12-11x65mm Hex Head Type 17 Class 3 screws (Care to be taken to NOT over torque screws)
13. Top Hat battens must be no less than 0.48mm BMT. For BMT less than 0.48mm contact Nasahi<sup>®</sup> Technical

☐ Reference Document: Clarkson Consulting services Report No:NAS\_24Span\_75\_v1.1 Dated 21 November 2024

---

# Impact Resistance

THE NASAHI® EXTERNAL WALL SYSTEM HAS BEEN DESIGNED TO PROVIDE EXCELLENT SOFT AND HARD BODY IMPACT RESISTANCE AND MEET ALL RELATED NCC REQUIREMENTS.

## DURABILITY

The Nasahi® External Wall System when subjected to typical conditions will provide many years of maintenance free service.

# Fire Resistance

THE NASAHİ® EXTERNAL WALL SYSTEM HAS BEEN DESIGNED TO COMPLY WITH FIRE RESISTANCE REQUIREMENTS OF THE NCC.

Nasahİ® Panels are inherently non-combustible, and in the event of fire Nasahİ® Panels do not emit toxic gases or vapours. The Nasahİ® External Wall System meets the performance requirements of the NCC, providing a Fire Resistance Level (FRL) of up to 120/120/120 using standard 10mm plasterboard internal lining.

## EXTERNAL WALL FIRE RESISTANCE LEVELS (FRL)

Table 8.0 - Nasahİ® External Wall Fire Resistance Levels (FRL), from outside direction only. (Refer to Table 8.1 for two-way FRL system configurations).

REQUIREMENT FOR EXTERNAL WALLS					
EXPOSED SIDE CLADDING	BATTEN*	WALL FRAMING	UNEXPOSED SIDE CLADDING	FRL	IMPOSED FIRE DESIGN LOAD (AS 1170.0 CLAUSE 4.2.4)
Nasahİ® Super <sup>50</sup> or Super <sup>75LD</sup> Min. 50mm	Steel batten	Min. 70mm deep timber or min. 76mm deep steel stud	10mm thick or greater standard grade plasterboard	120/120/120	Total axial load 11.5kN/m (equating to a total load of 34.6 kN)

## EXTERNAL WALL FIRE RESISTANCE LEVELS (FRL) FROM BOTH SIDES

Table 8.1 - Nasahİ® External Wall Fire Resistance Level (FRL) from both sides

CONSTRUCTION ARRANGEMENT FROM OUTSIDE TO INSIDE	FRL FROM OUTSIDE (EXPOSED CLADDING)	INTERNAL LINING / PLASTERBOARD	FRL FROM INSIDE DEPENDANT ON PROPRIETARY SYSTEM
<ul style="list-style-type: none"> <li>Nasahİ® Panel (Super<sup>50</sup> or Super<sup>75LD</sup>)</li> <li>Steel battens</li> <li>Min 70mm deep timber or min 76mm deep steel stud wall framing</li> <li>Internal plasterboard</li> </ul>	120/120/120	10mm standard plasterboard	-/-/-
		The FRL from the internal side of the wall system can be provided from an existing proprietary system which achieves the required FRL. The proprietary wall system is required to have sufficient evidence to achieve the required FRL. (Refer to Assurance Fire Assessment report ACTC-8363-99R I02R00 Issued 20.11.2024 Table 2A, Page 6)	30/30/30
			60/60/60
			90/90/90
			120/120/120
Nasahİ® Panel (50mm, 62 or 75mm)	120/120/120		

Notes:

1. Nasahİ do not specify the construction of the framing or the internal linings. The internal linings in particular will have specific installation instructions to meet FRL Requirements. This is not addressed in the External Wall Manual.

2. For exposure from internal (plasterboard) side: The stud spacings must not exceed 450mm. Timber stud must not be less than 45mm. Steel Stud BMT must not be less than 0.75mm.

☐ Reference Document: Warringtonfire Australia, Report No: FRT240161 Dated: 19th July 2024 Revision: 1.0

☐ Reference Document: Assurance Fire Assessment Report ACTC-8363-99R I02R00- Issued 20.11.2024

## BUSH FIRE ZONE COMPLIANCE

The Nasahi® External Wall System has been designed to comply with all six Bush Fire Attack Level categories (BAL) in the AS 3959:2018 Construction in Bush-fire Prone Areas.

### NASAHI® PANELS - SUPER<sup>50</sup> & SUPER<sup>75LD</sup>

Table 9 - Bush-Fire Zone Compliance

BAL	DESCRIPTION	REQUIREMENT FOR EXTERNAL WALLS	NASAHI®
Low	Minor attack from radiant heat and flame. Some attack by burning debris possible.	No special construction requirements.	✓
12.5	Significant attack by burning debris. Radiant heat not greater than 12.5kW/m <sup>2</sup> .	Non-combustible wall material required up to 400mm above ground or decks. Ember ingress protection required.	✓
19	Significant attack by burning debris. Radiant heat not greater than 19kW/m <sup>2</sup> .	Non-combustible wall material required up to 400mm above ground or decks. Ember ingress and radiant heat protection required.	✓
29	Significant attack by burning debris. Radiant heat not greater than 29kW/m <sup>2</sup> . Some flame contact is possible.	Non-combustible wall material required. Ember ingress and radiant heat protection required.	✓
40	Radiant heat levels and flame contact is likely to significantly threaten building integrity.	Non-combustible wall material required or tested for bushfire resistance to AS1530.8.1.	✓
FZ (Flame Zone)	Significant radiant heat and high likelihood of flame contact from the fire front threatening building integrity.	Non-combustible material with a minimum thickness of 90mm; or FRL of -/30/30 when tested from outside; or tested for bushfire resistance to AS1530.8.2	✓

#### Notes:

1. In bushfire applications, panels must not be installed in a manner that allows debris to accumulate underneath the panel. Burning ember ingress into the cavity must be prevented in accordance with NCC and AS3959 requirements.
2. The Nasahi External wall system achieves FZ compliance in accordance with Clause 9.4.1 AS 3959 (A system with an FRL of 30/30/30 when tested from the outside). Clause 3.4 AS 3969 states the construction requirements specified for a particular BAL shall be acceptable for a lower level.



# Energy Efficiency

THE NASAHI® EXTERNAL WALL SYSTEM HAS BEEN DESIGNED TO ACHIEVE ENERGY EFFICIENCY LEVELS THAT COMPLY WITH THE CLIMATE ZONE REQUIREMENTS OUTLINED IN THE NCC.

This exceptional level of performance is due to the aeration within the Nasahi® Panels providing very high levels of thermal resistance.

Table 10 - NCC 2022 External Wall Total R-Value Requirements by Climate Zone (Thermally bridged values)

CLIMATE ZONES	1,2,3,4,5	6,7	8
Minimum Total R-Value for External Walls	Typical wall – R2.8 Shaded with a minimum projection angle of: 15 degrees – R2.4	Typical wall – R2.8	Typical wall – R3.8

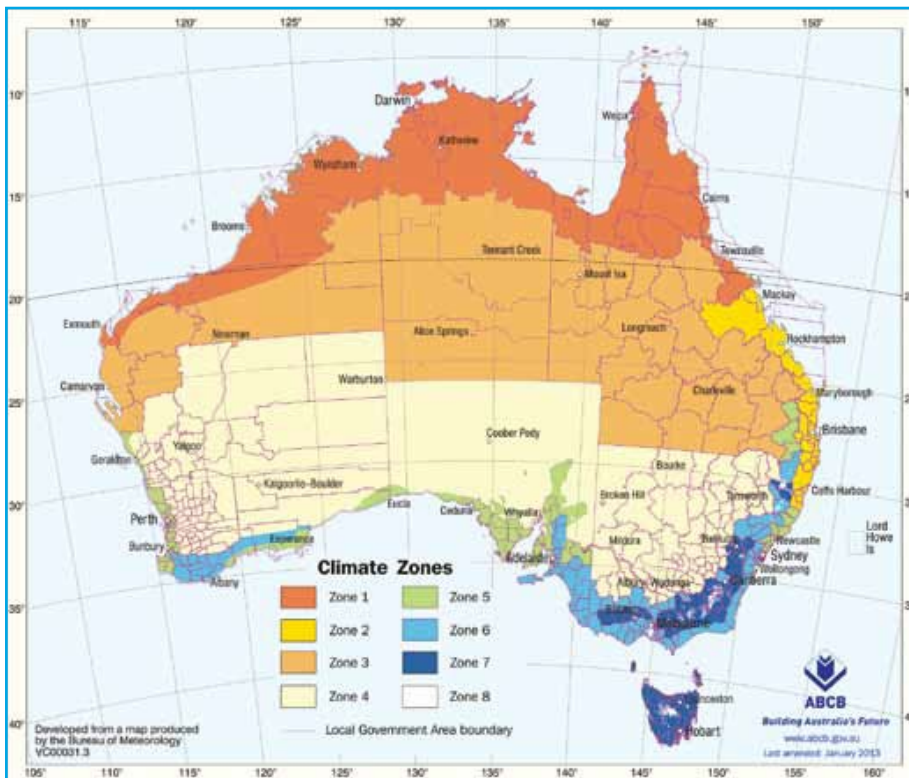

Image Sourced from the NCC 2022, Figure 2, page 572, Climate zones for thermal design.

## CLIMATE ZONE COMPLIANCE

Table 11 - Nasahi® Bare Panel Thermal Rating

PANEL THICKNESS	R VALUE
Super <sup>50</sup>	0.391m <sup>2</sup> K/W
Super <sup>75LD</sup>	0.721m <sup>2</sup> K/W

📄 Reference Clarkson Consulting services Report No: NAS\_24\_50 Thermal01\_v2.1 Dated 10 September 2024

📄 Reference Clarkson Consulting services Report No: NAS\_24\_75 Thermal01\_v2.0 Dated 14 June 2024



AN  
EXCEPTIONAL  
LEVEL OF  
PERFORMANCE

## THERMAL INSULATION COMPLIANCE

### Nasahi® 50mm AAC Cladding Insulation R Values

The Table below presents Total R-values in accordance with AS/NZS 4859.2 Parts 1 & 2:2018 incorporating the effects of thermal bridging. These values are equally applicable to all building types.

Table 12 - Thermal performance of vertically installed 50mm Nasahi® external wall system – Timber & Steel Frames

STRUCTURAL FRAME		TOP HAT BATTEN DEPTH (MM)	SARKING/WALL WRAP TYPE	BULK INSULATION R-VALUE	INTERNAL LINING	INSULATION PATH R-VALUE (M <sup>2</sup> .K/W)		TOTAL WALL R-VALUE (M <sup>2</sup> .K/W)	
TYPE & SPACING	STUD SIZE					WINTER	SUMMER	WINTER	SUMMER
Timber at 600mm Centres	70x35	15-35mm	At Stud Frame	-	10mm Plasterboard	R1.316	R1.306	-	-
			Foil Vapour Barrier	-		R1.386	R1.276	R1.380	R1.279
			Vapour Permeable	-		R0.956	R0.936	R0.989	R0.970
			Vapour Barrier or Permeable	R1.5		R2.286	R2.276	R2.197	R2.187
				R2.0		R2.786	R2.776	R2.652	R2.642
						R1.468	R1.458	-	-
	90x45		At Stud Frame	-		R1.386	R1.276	R1.396	R1.297
			Foil Vapour Barrier	-		R0.956	R0.936	R1.016	R0.997
			Vapour Permeable	-		R2.786	R2.776	R2.632	R2.622
			Vapour Barrier or Permeable	R2.0		R3.286	R3.276	R3.074	R3.064
				R2.5		R3.786	R3.776	R3.515	R3.505
				R3.0					
Timber at 450mm Centres	70x35	15-35mm	At Stud Frame	-	10mm Plasterboard	As Above		-	-
			Foil Vapour Barrier	-				R1.378	R1.279
			Vapour Permeable	-				R0.996	R0.977
			Vapour Barrier or Permeable	R1.5				R2.179	R2.169
				R2.0				R2.624	R2.614
								-	-
	90x45		At Stud Frame	-				R1.398	R1.302
			Foil Vapour Barrier	-				R1.028	R1.009
			Vapour Permeable	-				R2.601	R2.591
			Vapour Barrier or Permeable	R2.0				R3.031	R3.021
				R2.5				R3.460	R3.450
				R3.0					
Steel at 600mm Centres with R0.2 Thermal Break Type	76x35x 0.55BMT	15-35mm	At Stud Frame	-	10mm Plasterboard	R1.069	R1.059	-	-
			Foil Vapour Barrier	-		R1.386	R1.276	R1.357	R1.256
			Vapour Permeable	-		R0.956	R0.936	R0.966	R0.947
			Vapour Barrier or Permeable	R1.5		R2.286	R2.276	R2.175	R2.165
				R2.0		R2.786	R2.776	R2.629	R2.619
						R1.084	R1.074	-	-
	90x45x 0.55BMT		At Stud Frame	-		R1.386	R1.276	R1.351	R1.252
			Foil Vapour Barrier	-		R0.956	R0.936	R0.971	R0.952
			Vapour Permeable	-		R2.786	R2.776	R2.588	R2.578
			Vapour Barrier or Permeable	R2.0		R3.286	R3.276	R3.029	R3.019
				R2.5		R3.786	R3.776	R3.471	R3.461
				R3.0					
Steel at 450mm Centres with R.02 Thermal Break Type	76x35x 0.55BMT	15-35mm	At Stud Frame	-	10mm Plasterboard	As Above		-	-
			Foil Vapour Barrier	-				R1.351	R1.252
			Vapour Permeable	-				R0.968	R0.950
			Vapour Barrier or Permeable	R1.5				R2.152	R2.142
				R2.0				R2.597	R2.587
								-	-
	90x45x 0.55BMT		At Stud Frame	-				R1.344	R1.248
			Foil Vapour Barrier	-				R0.974	R0.955
			Vapour Permeable	-				R2.547	R2.537
			Vapour Barrier or Permeable	R2.0				R2.977	R2.967
				R2.5				R3.406	R3.396
				R3.0					

#### Notes:

1. Enclosed calculations are in accordance with AS/NZS 4859 Parts 1 & 2:2018.
2. The above calculations are for total overall R value of opaque wall elements (no glazing).
3. Wall framing elements and insulated areas taken into consideration for weighted average R values.
4. Winter and Summer T values for Australia as defined in AS/NZS 4859.2:2018.
5. Batten depth (15-35mm) has no influence on wall R values as air gaps are non-reflective.
6. Thermal Conductivity of Nasahi® AAC panels (~525 kg/m<sup>3</sup>), k = 0.128 W/m.K.

7. Emissivity of reflective foil vapour barrier membranes assumed to be 0.05.
8. Emissivity of non-reflective vapour permeable membranes assumed to be 0.8.
9. Insulation path R values calculated at main insulation cavity (reflective or non-reflective air spaces for no insulation options).
10. For U value calculation  $U = 1/R$ .

Reference Document: Clarkson Consulting services Report No: NAS\_24 50mm Therm01\_v2.1 Dated 10 September 2024

## THERMAL INSULATION COMPLIANCE

### Nasahi® 75mm AAC Cladding Insulation R Values

The Table below presents Total R-values in accordance with AS/NZS 4859.2 Parts 1 & 2:2018 incorporating the effects of thermal bridging. These values are equally applicable to all building types.

Table 12.1 - Thermal performance of vertically installed 75mm Nasahi® external wall system – Timber or Steel Stud Frames

STRUCTURAL FRAME		TOP HAT BATTEN DEPTH (MM)	SARKING/WALL WRAP TYPE	BULK INSULATION R-VALUE	INTERNAL LINING	INSULATION PATH R-VALUE (M <sup>2</sup> .K/W)		TOTAL WALL R-VALUE (M <sup>2</sup> .K/W)		
TYPE & SPACING	STUD SIZE					WINTER	SUMMER	WINTER	SUMMER	
Timber at 600mm Centres	70x35	15-35mm	At Stud Frame	-	10mm Plasterboard	R1.647	R1.637	-	-	
			Foil Vapour Barrier	-		R1.717	R1.607	R1.710	R1.609	
			Vapour Permeable	-		R1.287	R1.267	R1.319	R1.300	
			Vapour Barrier or Permeable	R1.5		R2.616	R2.606	R2.528	R2.518	
				R2.0		R3.117	R3.107	R2.982	R2.972	
			90x45	At Stud Frame		-	R1.798	R1.788	-	-
	Foil Vapour Barrier			-		R1.717	R1.607	R1.726	R1.628	
	Vapour Permeable			-		R1.287	R1.267	R1.346	R1.327	
	Vapour Barrier or Permeable			R2.0		R3.117	R3.107	R2.963	R2.953	
				R2.5		R3.617	R3.607	R3.405	R3.395	
	R3.0			R4.116		R4.106	R3.846	R3.836		
	Timber at 450mm Centres		70x35	15-35mm		At Stud Frame	-	10mm Plasterboard	As Above	As Above
Foil Vapour Barrier		-			R1.709	R1.610				
Vapour Permeable		-			R1.326	R1.307				
Vapour Barrier or Permeable		R1.5			R2.510	R2.500				
		R2.0			R2.955	R2.945				
90x45		At Stud Frame			-	-	-			
		Foil Vapour Barrier	-		R1.728	R1.632				
		Vapour Permeable	-		R1.359	R1.340				
		Vapour Barrier or Permeable	R2.0		R2.931	R2.921				
			R2.5		R3.361	R3.351				
		R3.0	R3.791		R3.781					
Steel at 600mm Centres with R0.2 Thermal Break Type		76x35x 0.55BMT	15-35mm		At Stud Frame	-	10mm Plasterboard			
	Foil Vapour Barrier			-	R1.717	R1.607		R1.688	R1.587	
	Vapour Permeable			-	R1.287	R1.267		R1.297	R1.278	
	Vapour Barrier or Permeable			R1.5	R2.616	R2.606		R2.505	R2.495	
				R2.0	R3.117	R3.107		R2.960	R2.950	
	92x45x 0.55BMT			At Stud Frame	-	R1.414		R1.404	-	-
		Foil Vapour Barrier		-	R1.717	R1.607		R1.681	R1.583	
		Vapour Permeable		-	R1.287	R1.267		R1.301	R1.283	
		Vapour Barrier or Permeable		R2.0	R3.117	R3.107		R2.918	R2.908	
				R2.5	R3.617	R3.607		R3.360	R3.350	
		R3.0		R4.116	R4.106	R3.801		R3.791		
	Steel at 450mm Centres with R.02 Thermal Break Type	76x35x 0.55BMT		15-35mm	At Stud Frame	-		10mm Plasterboard	As Above	As Above
Foil Vapour Barrier			-		R1.682	R1.583				
Vapour Permeable			-		R1.299	R1.280				
Vapour Barrier or Permeable			R1.5		R2.483	R2.473				
			R2.0		R2.928	R2.918				
92 x45x 0.55BMT			At Stud Frame		-	-	-			
		Foil Vapour Barrier	-		R1.674	R1.578				
		Vapour Permeable	-		R1.305	R1.286				
		Vapour Barrier or Permeable	R2.0		R2.877	R2.867				
			R2.5		R3.307	R3.297				
		R3.0	R3.737		R3.727					

#### Notes:

1. Enclosed calculations are in accordance with AS/NZS 4859 Parts 1 & 2:2018.
2. The above calculations are for total overall R value of opaque wall elements (no glazing).
3. Wall framing elements and insulated areas taken into consideration for weighted average R values.
4. Winter and Summer T values for Australia as defined in AS/NZS 4859.2:2018.
5. Batten depth (15-35mm) has no influence on wall R values as air gaps are non-reflective.
6. Thermal Conductivity of Nasahi® AAC panels (~525 kg/m<sup>3</sup>), k = 0.128 W/m.K.
7. Emissivity of reflective foil vapour barrier membranes assumed to be 0.05.
8. Emissivity of non-reflective vapour permeable membranes assumed to be 0.8.
9. Insulation path R values calculated at main insulation cavity (reflective or non-reflective air spaces for no insulation options).
10. For U value calculation U = 1/R.

Reference Document: Clarkson Consulting services Report No: NAS\_24 50mm Therm01\_v2.1 Dated 10 September 2024



## THERMAL INSULATION COMPLIANCE (CONTINUED)

### Notes

To accommodate for the major thermal bridging paths through external wall construction the R values of the main construction elements and insulated elements combine to provide a whole of wall system thermal performance. This is calculated in accordance with AS/NZS 4859.2-2018, whereby a weighted average R value is assigned to the key elements.

All bulk insulation supplied shall be in accordance with AS4859.1:2002 Materials for thermal insulation of buildings, bulk insulation shall be installed in accordance with manufacturer's instructions and AS3999:2015 Bulk thermal insulation – Installation.

1. Friction fit the insulation into the wall frames ensuring no gaps between the insulation and studs or noggings.
2. It is important that the insulation is secured so it cannot sag or fall.
3. Where required cut batt to suit the requirements of the width between the timber studs.
4. Ensure that the insulation does not protrude past the stud and fits snugly including where insulation is around water pipes or other rigid obstructions in the wall.
5. Butt the batts closely together to ensure there are no gaps left at joints.
6. Do not compress the insulation to fit around obstructions.

 *Reference Clarkson Consulting services Report No: NAS\_24\_50 Thermal01\_v2.1 Dated 10 September 2024*

 *Reference Clarkson Consulting services Report No: NAS\_24\_75 Thermal01\_v2.0 Dated 14 June 2024*

# Condensation Management

IN ORDER TO COMPLY WITH THE NEW CONDENSATION REQUIREMENTS IN THE NCC 2022, NASAHI® HAS APPOINTED SPECKEL CONSULTING TO UNDERTAKE 1D HYGROTHERMAL ASSESSMENT ON OUR NASAHI® EXTERNAL AND BOUNDARY WALL SYSTEMS.

The summary below applies to boundary and typical external wall types, representing worst-case moisture loading based on a typical based on a typical 3-bedroom home of 260m<sup>3</sup> NCC Volume 2 (Class1) and a typical 2-bedroom apartment of 168m<sup>3</sup> NCC Volume 1 (Class 2).. The results are not applicable to smaller volumes, as moisture loads will be higher.

Cavities were modelled at worst-case depths; increasing the depth from 16mm will enhance drying and moisture control.

Worst-case climate files were used for all zones, making the results relevant to multiple localities.

Extreme climates within a zone, such as high-altitude areas, may need independent review.

Table 12.2 - Condensation management

	CLIMATE ZONE	LOCALITY	PANEL THICKNESS	PANEL THICKNESS	MOULD GROWTH INDEX <3.0
A typical 3-bedroom Class 1 of 260 m <sup>3</sup>  NCC Volume 2 Domestic or Residential Buildings	5	Sydney, Perth	Boundary	37mm - 75mm	Pass
			Typical External		Pass
	6	Melbourne, Perth	Boundary		Pass
			Typical External		Pass
	7	Hobart, Canberra	Boundary		Pass
			Typical External		Pass
	1, 2 and 3	Darwin (Brisbane & Alice Springs)	Boundary		Pass
			Typical External		Pass
	CLIMATE ZONE	LOCALITY	PANEL THICKNESS	PANEL THICKNESS	MOULD GROWTH INDEX <3.0
A typical 2-bedroom Class 2 of 168 m <sup>3</sup>  NCC Volume 1 Domestic Apartment Buildings	5	Sydney, Perth	Boundary	37mm - 75mm	Pass
			Typical External		Pass
	6	Melbourne, Perth	Boundary		Pass
			Typical External		Pass
	7	Hobart, Canberra	Boundary		Pass
			Typical External		Pass
	1, 2 and 3	Darwin (Brisbane & Alice Springs)	Boundary		Pass
			Typical External		Pass

Note: The findings apply to the studied wall types and a typical 3-bedroom home of 260 m<sup>3</sup> (Class 1) or typical 2-bedroom apartment of 168 m<sup>3</sup> (Class 2) only. Deviation from any assumptions presented herein will present alternative outcomes. The builder/designer must ensure adequate mechanical ventilation or air-condition systems are incorporated in accordance with AS 1668.2. Any home with larger cavities (up to 45 mm) would enhance drying and moisture control. Localities in extreme climates or smaller volumes may need independent review.

Report No. 0259(02)Nasahi\_Hygrothermal\_Assesments  
NCC Volume 2 (Class1) and NCC Volume 1 (Class 2) Date 27.11.2024

# Acoustic Performance

THE NASAHI® EXTERNAL WALL SYSTEM HAS BEEN DESIGNED TO PROVIDE EXCELLENT ACOUSTIC PERFORMANCE.

Sound insulation materials can be incorporated into the system to significantly increase the acoustic performance against outside noise.

A complete listing of Nasahi® External Wall System acoustic performance may be found on our website.

A 10db increase in acoustic performance is approximately equivalent to a halving of loudness.

Table 13 - Typical Acoustic Performances of External Walls Comparative thickness (mm)

DESCRIPTION	SYSTEM THICKNESS (MM)	ACOUSTIC PERFORMANCE $R_w+C_{tr}$
Nasahi® Super <sup>50</sup> External Wall System, 4mm render, minimum 16mm Batten, 90mm timber frame, R2 Insulation, 10mm Plasterboard.	170	43
Nasahi® Super <sup>75LD</sup> External Wall System, 4mm render, minimum 16mm Batten, 90mm timber frame, R2 Insulation, 10mm Plasterboard.	195	44
Brick veneer, Timber Frame and Internal Plasterboard	250	50
Rendered EPS, Timber Frame and Internal Plasterboard	174	29
Weatherboards, Timber Frame and Internal Plasterboard	120	23

Note: For external walls, there are no acoustic requirements for external walls for Class 1, 2, 3 or 9C buildings. Please refer to codes and policies within your State or Territory, and Council Planning Policies for external wall acoustic requirements for developments near rail corridors, busy roads, and/or under flight paths.

Reference Document: Renzo Tonin & Associates, Acoustic Opinions Report No. TH736-01F02 (r17, Dated 16th September 2024.

---

# Weatherproofing

## PLIABLE WALL MEMBRANES

Wall wrap in accordance with AS/NZS 4200.1:2017 must be used with the Nasahi® External Wall System to ensure a cavity is maintained between the Nasahi® Panel and insulation, which further improves the energy efficiency of the system.

The wall wrap must comply with relevant condensation management provisions of the NCC and be installed in accordance with AS 4200.2:2017 including taping at all joins and edges.

The Nasahi® External Wall System has been tested to meet the performance requirements of the NCC. In the event that water enters the wall cavity, the system is designed to allow excess moisture present to be dissipated without causing permanent damage to the building elements.

The system is designed with four layers of defense to prevent moisture entry into the habitable space:

- External Coating
- Nasahi® Panel
- Internal Cavity
- Pliable Wall Membrane

*Note: External Coatings and Wall wraps are not required for Boundary Wall applications for up to N2 wind classifications. Ensure the Boundary Wall is weatherproofed at the top, bottom and sides.*

## Sealants

All control Joints must be sealed with a suitable external grade acoustic and/or fire rated paintable sealant. All gaps between the Nasahi® panels and framing around the windows and doors must be sealed.

Minimum 2 hour fire rating caulking should be used for fire rated applications. Wall wrap must be installed in accordance with AS 4200.2:2017 including taping at all joins and edges.

## Wall Flashings

Flashings shall be designed and installed in accordance with AS 2904 DPC & Flashing Installation Code for Metal Roofing and Wall Cladding.

## Penetrations

Penetrations must be sealed and flashed in accordance with the Nasahi® construction details provided, and the NCC. It is the responsibility of the project engineer to verify that all non-standard installation details will meet the performance requirements of the NCC.

In the event of a Boundary Wall System (with no penetrations) abutting the boundary wall of an adjoining property that cannot be coated, the uncoated Boundary Wall System must be installed with a drained cavity between abutting walls, and be weatherproofed at the top and sides, as shown in details 11.0 on Page 63.



---

## ENVIRONMENTAL

Nasahi® delivers a diverse number of environmental benefits over bricks and concrete. As environmental consciousness and social responsibility increases, Nasahi® is striving to set new sustainability standards in building materials and residential living.



# Nasahi® Building Smarter

## TYPICAL TIMBER OR STEEL HOME FRAMING CONSTRUCTION

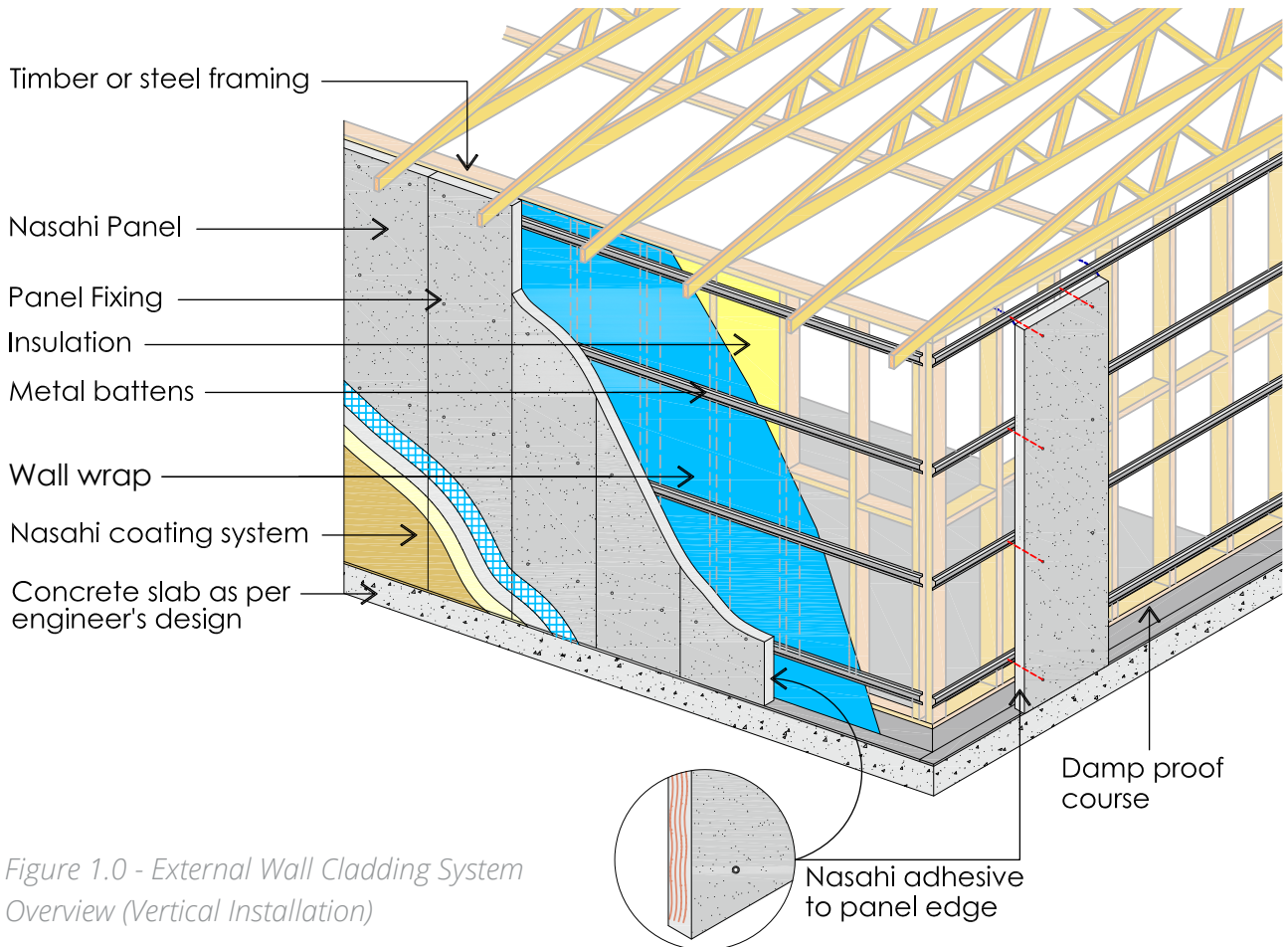
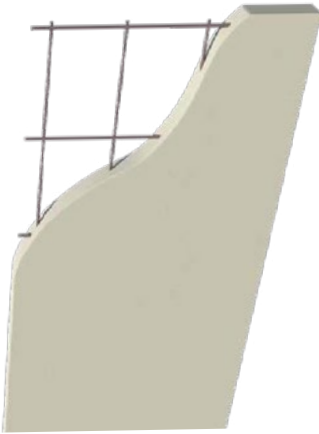

Figure 1.0 - External Wall Cladding System Overview (Vertical Installation)

# External Wall System Components

System Components for Timber Frame



## NASAHI® PANELS

Nasahi® panels are manufactured from Autoclaved Aerated Concrete (AAC), embedded with coated steel reinforcement mesh, in standard thickness of 50mm and 75mm.

Table 14 - Panel length and thickness in mm

<b>SUPER<sup>50</sup> x 600 WIDE</b>	<b>SUPER<sup>75LD</sup> x 600 WIDE</b>
Stock lengths of 2400, 2500, 2700, 2850 and 3000	Stock lengths of 2400, 2500, 2700, 2850 and 3000

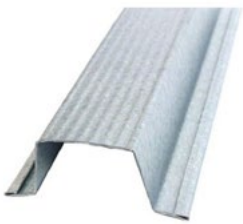

## METAL BATTENS

Table 15 - Metal Batten (Top Hat)

<b>16MM METAL BATTEN (TOP HAT)</b>	<b>24MM METAL BATTEN (TOP HAT)</b>	<b>35MM METAL BATTEN (TOP HAT)</b>
Cold-Formed	Cold-Formed	Cold-Formed
Minimum thickness 0.48BMT Minimum yield strength 550MPa (zincalume)	Minimum thickness 0.48BMT Minimum yield strength 550MPa (zincalume)	Minimum thickness 0.55mmBMT Minimum yield strength 270MPa (zincalume)
Coating Class AZ 150 (see Durability)	Coating Class AZ 150 (see Durability)	Coating Class AZ 275 (see Durability)



## DPC

Damp-Proof Courses must comply with AS2904, and be installed in accordance with NCC requirements. DPC shall be located below the AAC Panel on the lowest floor. Alternatively it could be on every floor.

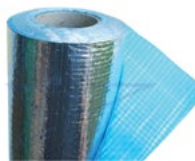

## WALL WRAP

The wall wrap material must be in accordance with AS/NZS 4200.1:2017 with water barrier and vapour permeable classifications and installed in accordance with AS 4200.2:2017.



## INSULATION

Provided wall insulation between each stud to achieve the required R-Value, refer to the thermal values section of these technical notes. Use non-combustible insulation where non-combustible construction is required.

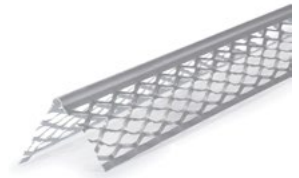

## ADHESIVE

Nasahi® Adhesive comes in 20kg bags and is used to glue and seal panel joints, and to fill screw heads.

## TOUCH-UP PAINT

If Nasahi® Panels are cut to size, all exposed reinforcing steel must be treated with Nasahi® Corrosion Protection Touch-up Paint in accordance with the instructions on the container.

## RENDER BEAD

Aluminum Render Bead is used to provide consistent neat vertical & horizontal control joints.

## PANEL FASTENERS

### Panel fasteners for Super<sup>50</sup> Panel



Hex Head - 14-10 x 65  
Type 17 Min Class 3  
Screw (Panel to Metal  
Batten)

OR

Bugle Batten Head  
Type17 14-10 x 75  
Class 3 Screws

**For Standard Density Only**

### Panel Fasteners for Super<sup>75LD</sup> Panels



Hex Head-14-10 x 90  
Type 17 Class 3 Screw  
(Panel to Metal Batten)

**Note:** In accordance with AS 3566.2 Class 3 fasteners must be used for moderate and mild exposure environment. Class 4 for severe marine further than 100m from breaking surf, marine and industrial exposure environments. Class 4 stainless steel for severe marine exposure environments within 100m of breaking surf.

## BATTEN FASTENERS

Fixing top hats to Timber and Steel stud frames as noted below.

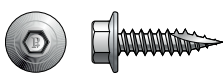

### Timber Frames

12-11 x 35mm Hex Head  
Type 17 Class 3 screws

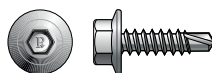

### Steel Frames

10-16 x 20mm Hex Head  
Self-Drilling Class 3 Screws

## BATTEN CLIP

For Boundary Wall applications.



311D Rondo  
Direct



314 Rondo Direct  
Fix Clip

---

# External Wall System Installation Sequence

## STAGE 1: PREPARATION

1. The roof and wall frame must be completed prior to installation of panels. A pre-installation check list is available on our website.



2. Damp-Proof Course must comply with AS2904, and be installed in accordance with NCC requirements. DPC shall be located at ground slab level.

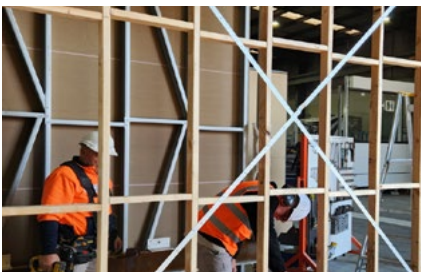

3. Ensure framing is plumb and straight. Pay particular attention to corner studs ensuring they are straight and plumb.

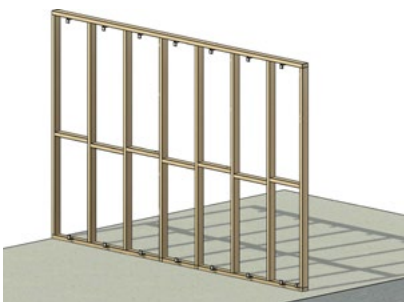

4. Install wall wrap in accordance with AS4200.2, ensuring that it overlaps the DPC at the base.

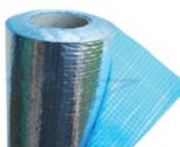

## STAGE 2: BATTEN INSTALLATION

5. Attach battens horizontally by fixing them to each stud. Batten spacing must comply with Nasahi® wind zone tables. All battens should be discontinuous at Control Joint locations. Check battens with string line and pack battens where required to maintain a straight and plumb line for panel installation. Install battens above and below opening as detailed in installation guide.

6. Flashings must be installed around penetrations in accordance with NCC requirements and to comply with project drawings.

## STAGE 3: NASAHI® PANEL INSTALLATION

7. Starting at a corner, rest the Nasahi® Panel on the slab rebate, push the panel hard up against the battens.

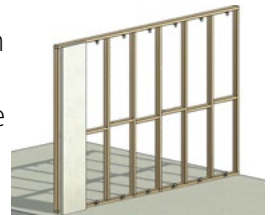

8. Using a spirit level ensure that the Nasahi® Panel is plumb and level and is either flush or overhanging the slab edge rebate as required by the project details.



9. Screw fix through the exterior face of the Nasahi® Panel and into the batten. screw spacing and number must comply with Nasahi® wind zone tables. Screws must be a minimum of 100mm in from the panel edge.

10. The screw head must penetrate 5-10mm below the panel face.

11. The Nasahi® Panels can be cantilevered a max of 250mm past the last batten.

#### STAGE 4: PANEL ADHESIVE

12. Mix adhesive to a thick flow-able consistency, apply approximately 2-3mm thick of the Panel Adhesive to vertical edge of the panel. Install the next panel ensuring it is level and joint is fully filled with adhesive.

13. Screw fix panel as per Step 9 above.

14. Repeat process around the perimeter of the building.

15. Ensure all panel joints are fully filled with adhesive other than Control joint locations. At these locations a 10mm gap must be maintained between adjoining panels and later filled with appropriate sealant.

16. Install panels below and above opening in a vertical orientation. If panel height is less than or equal to 600mm the panel can be installed horizontally. Repeat process around the perimeter of the building.

17. If panels are cut, all exposed steel reinforcement must be treated with Nasahi® Anti-Corrosion Touch up Paint.

18. Penetrations and Services must be sealed in accordance with the Plumbing and Electrical Service Section.

19. Install backing rod and suitable sealant to all control joints and perimeter of openings to Nasahi® details.

20. Fill screw holes using Nasahi® adhesive and allow to dry. Lightly sand, patched screw holes and sand any panels which are slightly misaligned. Lastly cut any projecting DPC at the base prior to applying a suitable render and texture system to panels.

21. Upon project completion the installer and renderer must both complete a Nasahi® Compliance Certificate and submit to both the builder and Nasahi®.

#### STAGE 5: COATINGS

Refer to Page 14 and 15.

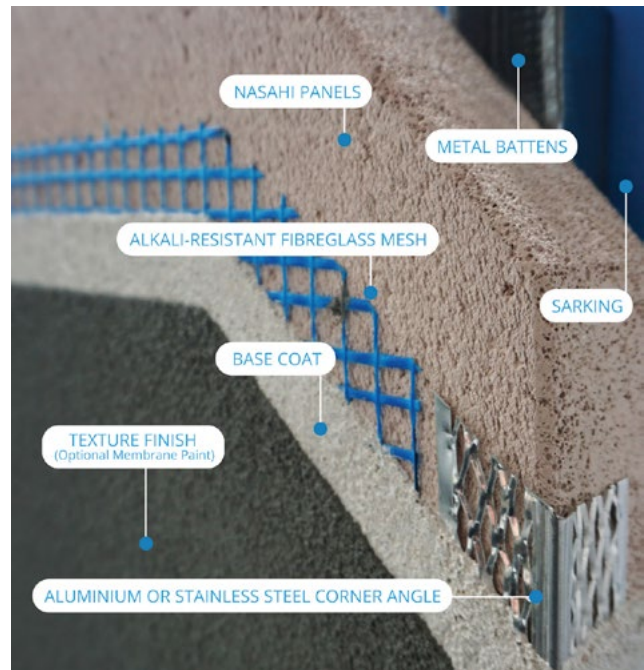



# NCC Compliance



## NCC VOLUME ONE

Covers commercial, residential and public buildings defined as Class 2 to 9. Typical examples include multi-family dwellings, commercial, health buildings and anything not covered under Volume Two.

It is the responsibility of the builder to ensure the system is designed in accordance with this installation manual and that all site-specific performance provisions outlined in the relevant sections of the NCC are met.

## NCC VOLUME TWO

Covers domestic constructions defined as Class 1 and 10. Typical examples include single-family dwellings, townhouses, houses and garages.

The Nasahi® External Wall System has been certified to meet the following provisions of the National Construction Code for Volume One and Volume Two as listed below:

Table 16 - NCC Compliance

NCC COMPLIANCE SUPER <sup>50</sup> & SUPER <sup>75LD</sup>	VOLUME ONE	VOLUME TWO	ABSC HOUSING PROVISION
	Performance Provision Deemed to Satisfy	Performance Provision Deemed to Satisfy	Refer to Deemed to Satisfy
Structural	B1D4 (b)(ii)	H1D7 (4)(a)	-
Fire	C2D2 (Spec 5), C2D10, C2D11	H3D3	-
Bushfire	G5D3, G5D4	H7D4	-
Damp proofing & Weatherproofing	F1D6, F3D5 (1) (b)	H2D6 (4) (Weatherproofing)	5.7.3, 5.7.4 (DPC)
Energy Efficiency	J3D8, J4D6	H6D2 (1)(b) (refer to Housing Prov)	13.2.5
Condensation	F8D3	H4D9	10.8.1
Acoustic	There are no acoustic requirements for External walls for Class 1, 2, 3 or 9C buildings. Please refer to codes and policies within your State or Territory, and Council Planning Policies for external wall acoustic requirements for developments near rail corridors, busy roads, and/or under flight paths.		

Note: \* The Nasahi® External Wall System contributes to compliance with the above performance clauses, however, may not provide complete compliance for your project.

The Nasahi® CodeMark Certificate can be downloaded from our website [www.nasahi.net.au](http://www.nasahi.net.au). Nasahi® have developed a Performance Based Design Brief (PBDB) Template for use by registered professionals. For a copy please email [sales@nasahi.net.au](mailto:sales@nasahi.net.au) or call 1300 26 27 24.



# Appendix

## MATERIAL PROPERTIES

Appendix Table 17 - Material Properties for Super<sup>50</sup> and Super<sup>75LD</sup> Panels

PROPERTY		STANDARD DENSITY	LOW DENSITY <sup>LD</sup>	UNITS
Panel Thickness $d$		50 & 75	75 only	mm
Panel Width $w$			600	mm
Panel Length $L$		1800 up to 3000 for 50mm 1800 up to 3300 for 75mm	1800 up to 3300	mm
Panel edge profile		Square Edge		
AAC Dry Density, $\rho$	AS 5146.2 Appendix C	525	435	kg/m <sup>3</sup>
AAC Density for design, $\rho_d$	AS 5146.2	590	490	kg/m <sup>3</sup>
AAC Density for transport and lifting, $\rho_{tran}$	AS 5146.2	775	650	kg/m <sup>3</sup>
AAC Characteristic Compressive Strength, $f_{ck}$	AS 5146.2 Appendix D	3.1	2.0	MPa
Characteristic Ultimate Limit State Bending Moment Capacity ( $M_k$ )	AS 5146.2 Appendix E	0.34	0.78	kNm/m
Reinforcing yield stress	AS 4671	>500	>500	MPa
Reinforcing tensile strength	AS 4671	>600	>600	MPa
Reinforcing weld strength	AS 4671	>0.5 of force at yield of a longitudinal bar		
Design Serviceability Limit State Deflection Limit, max	AS 5146.1	SPAN/250		
Youngs Modulus (E)	AS5146.2:2018	1800		MPa

Notes:

1. Dry density is achieved by oven drying specimens so that the moisture content is close to 0%.
2. A design density of 590kg/m<sup>3</sup> has been calculated using a 12.4% moisture content.
3. A design density of 490kg/m<sup>3</sup> has been calculated for 75mm panels using a 12.4% moisture content.

# MANUFACTURING TOLERANCES REINFORCEMENT LAYOUT

## Manufacturing tolerances

Length	± 5mm
Width	± 1.5mm
Thickness	± 1.5mm
Diagonals (max.)	5mm
Edge Straightness Deviation (max.)	1.5mm

## 50mm Panel reinforcing bars

Length (mm)	Longitudinal bars (No.)	Dia. (mm)	Transverse bars (No.)	Dia. (mm)
2400	4	4.0	8	3.0
2550	4	4.0	8	3.0
2700	4	4.0	9	3.0
2850	4	4.0	10	3.0
3000	4	4.0	10	3.0

## Panel weight (For Standard and Lightweight Density.)

Density Description	SD	LD	SD
Thickness (mm)	50	75	75
Transport Density (kg/m <sup>3</sup> )	775	650	775
Length (mm)	Panel weight (kg)		
2400	56	70	84
2550	59	75	89
2700	63	79	94
2850	66	83	99
3000	70	88	105
3300	-	97	115
SD = Standard Density		LD = Low Density	

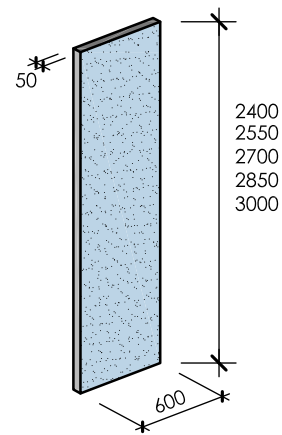

## Panel Re-bar Section

### 50mm Square Edge Panels

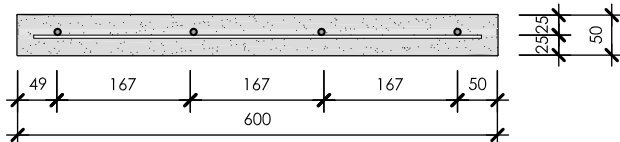

Typical 50mm Nasahi® Square Edge Panel section for 1800 - 3000mm panel length.

### 75mm Square Edge Panels

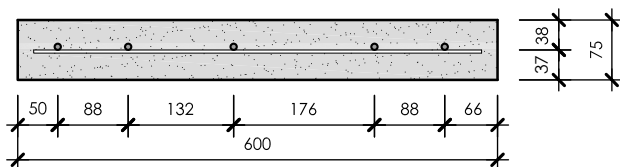

Typical 75mm Nasahi Square Edge Panel section for 2400 - 3300mm panel length.

## 75mm Panel reinforcing bars

Length (mm)	Longitudinal bars (No.)	Dia. (mm)	Transverse bars (No.)	Dia. (mm)
2400	4	4.0	6	4.0
2550	4	4.0	6	4.0
2700	5	4.0	7	4.0
2850	5	4.0	7	4.0
3000	5	4.0	8	4.0
3300	5	4.0	8	4.0

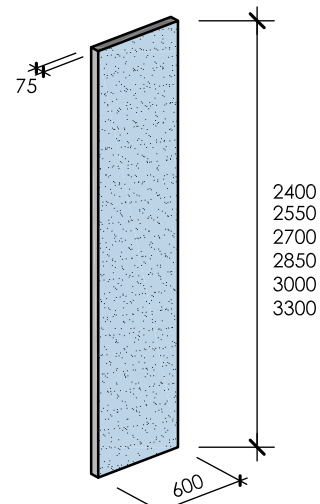

### Note:

Cutting: Panels typically to be no less than 270mm wide.

# SYSTEM OVERVIEW

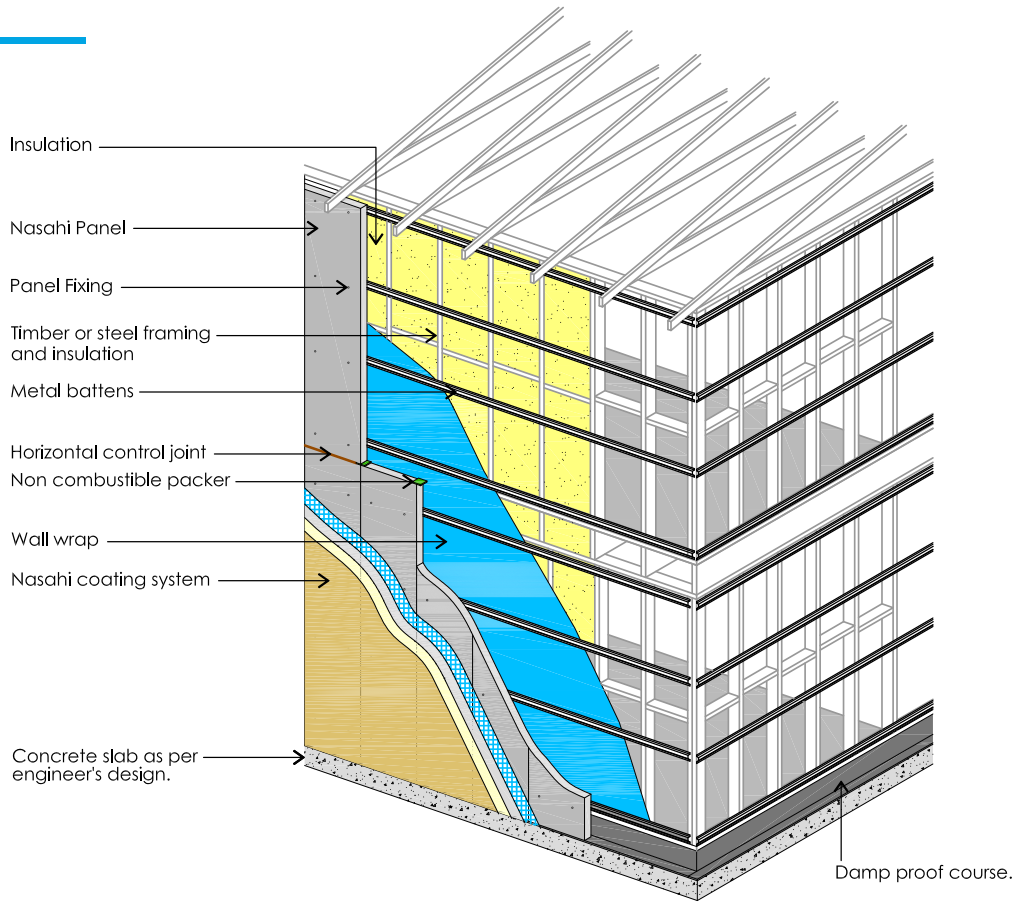
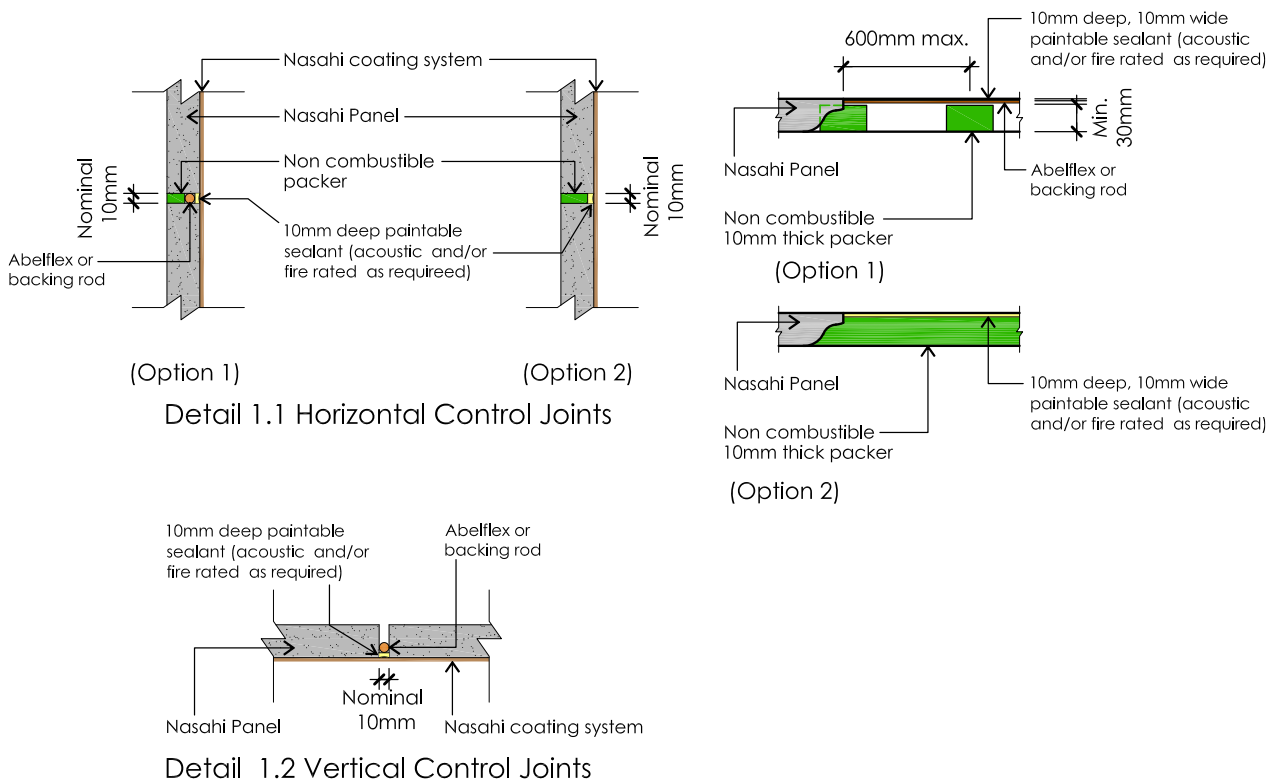
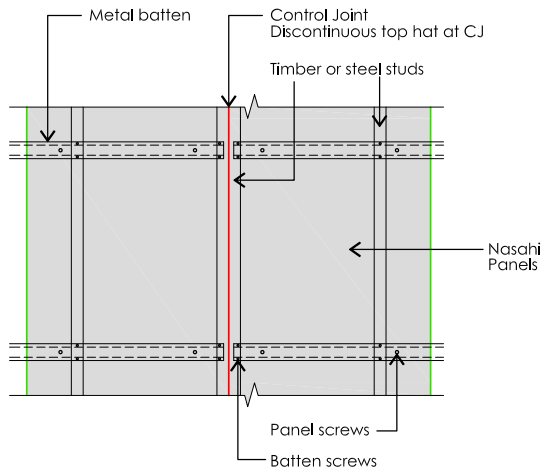

Fig 2.0 External Wall Cladding System Overview



# DETAIL DRAWINGS



Detail 1.3 Control Joint  
(Aligned metal battens on double studs)

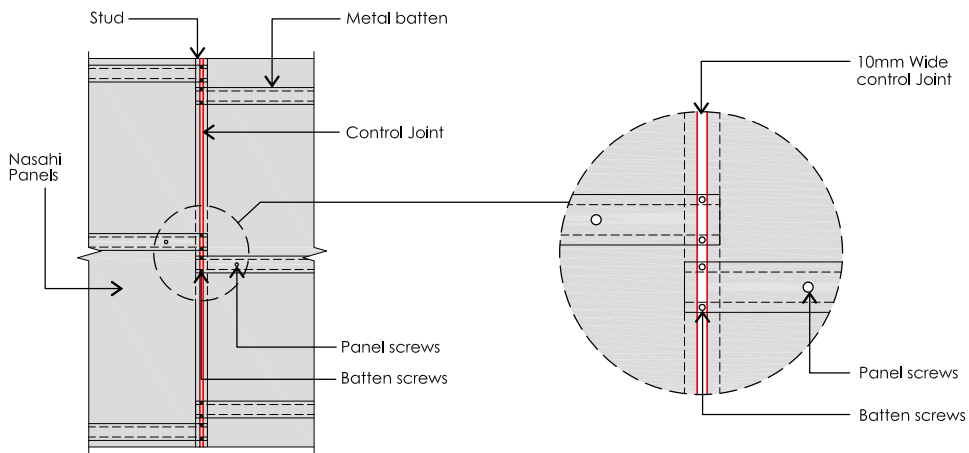

Detail 1.4 Control Joint  
(Discontinuous metal batten on single stud)

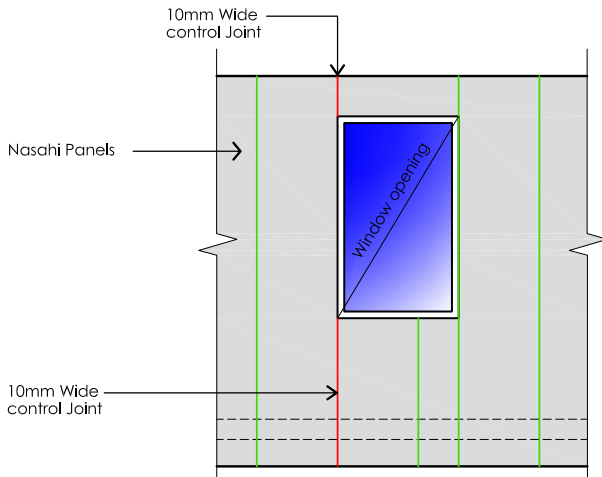

Detail 1.5 Typical Window Control Joint

Vertical control joints length	Opening Width		
	< 2400mm	2400mm to 3600mm	≥ 3600mm
< 600mm	1 control joint	2 control joints	2 control joints
≥ 600mm	No control joint	1 control joint	

**Note:**  
Maximum spacing between control joints must be adhered to on Page 13, Table 2.



DETAIL  
DRAWINGS

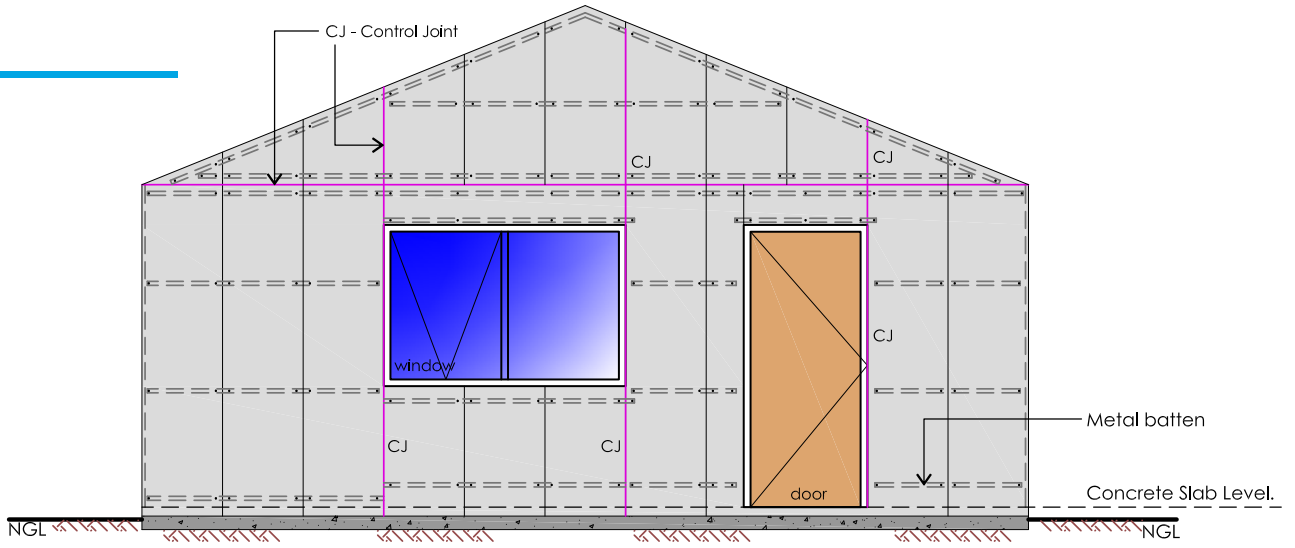

Detail 2.0 Panel Layout Guideline

(Gable End)

Note:

Number of metal battens and spacing to be confirmed by the building designer.

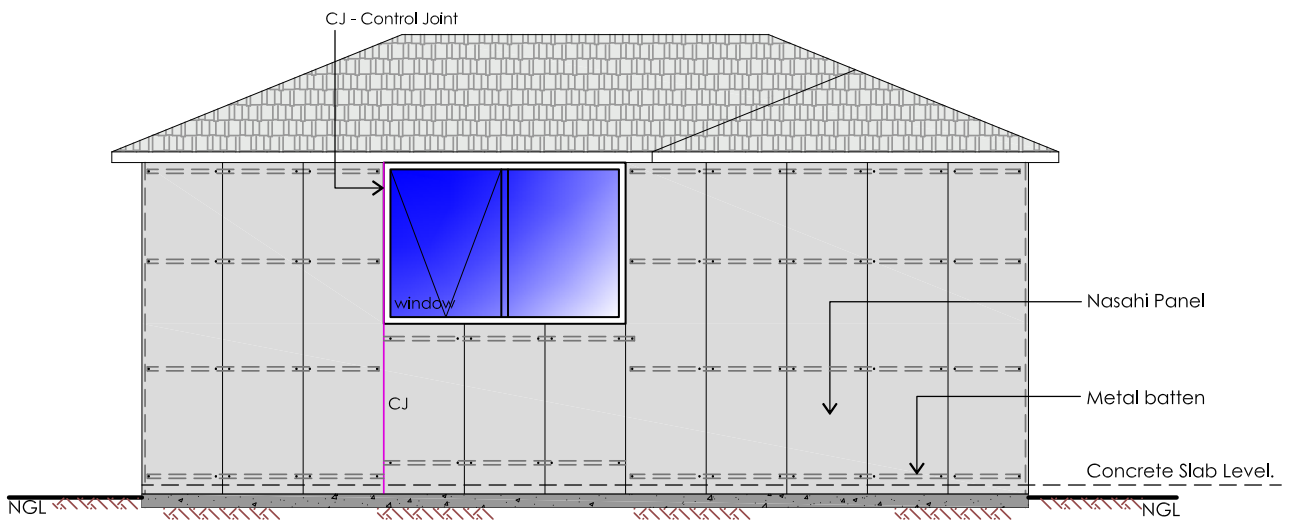

Detail 2.1 Panel Layout Guideline

(Pitch Hip roof)

# DETAIL DRAWINGS

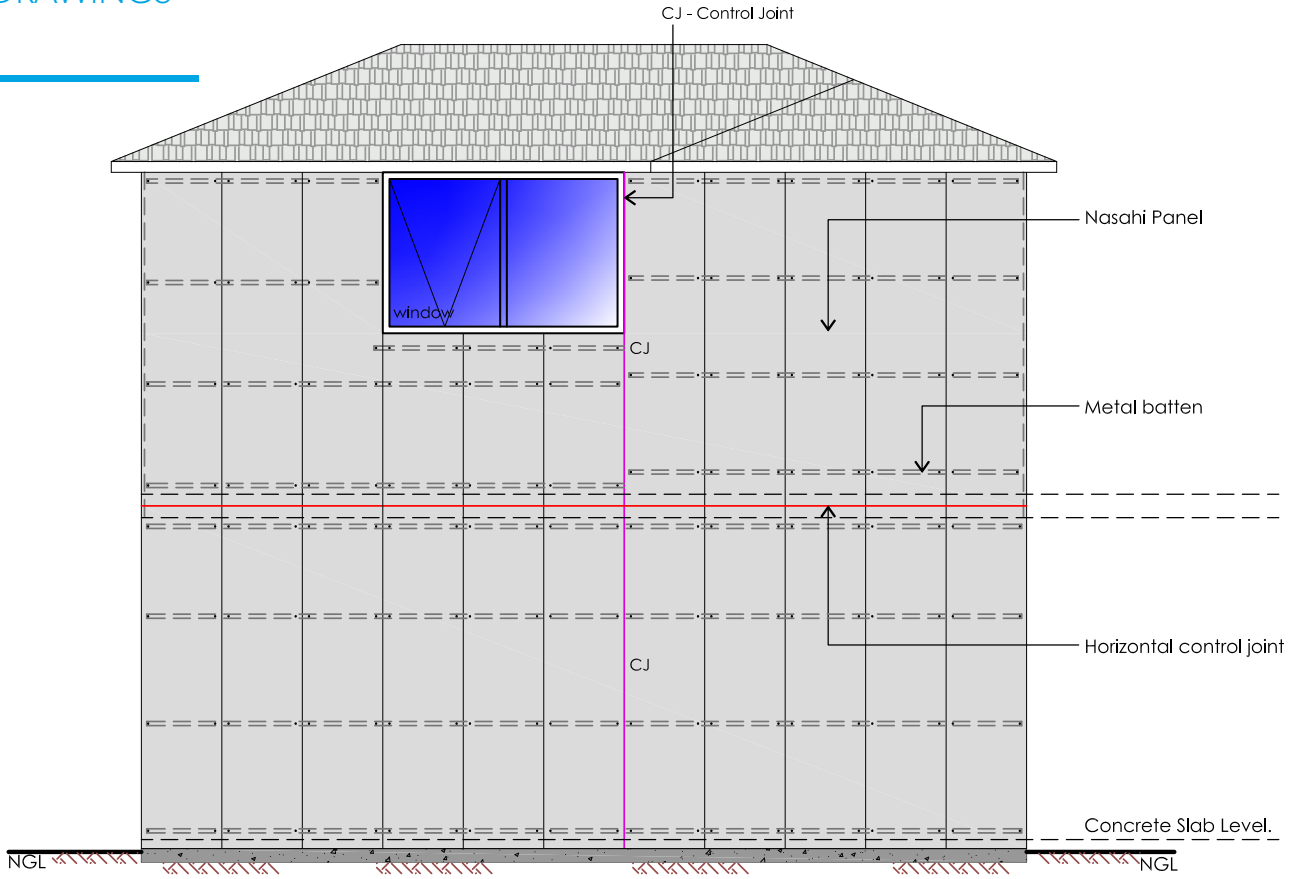

## Detail 2.2 Panel Layout Guideline

(Pitch Hip roof)

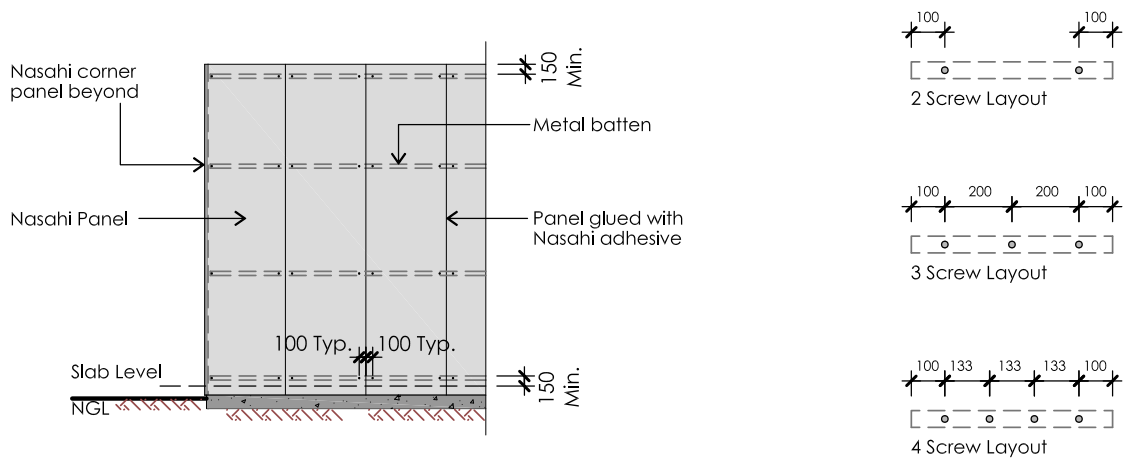

## Detail 2.3 Screw Fixing Layout

**NOTE:**  
Refer to Page 18 to 21  
Tables 7.0 to 7.7 for number  
of screws required.

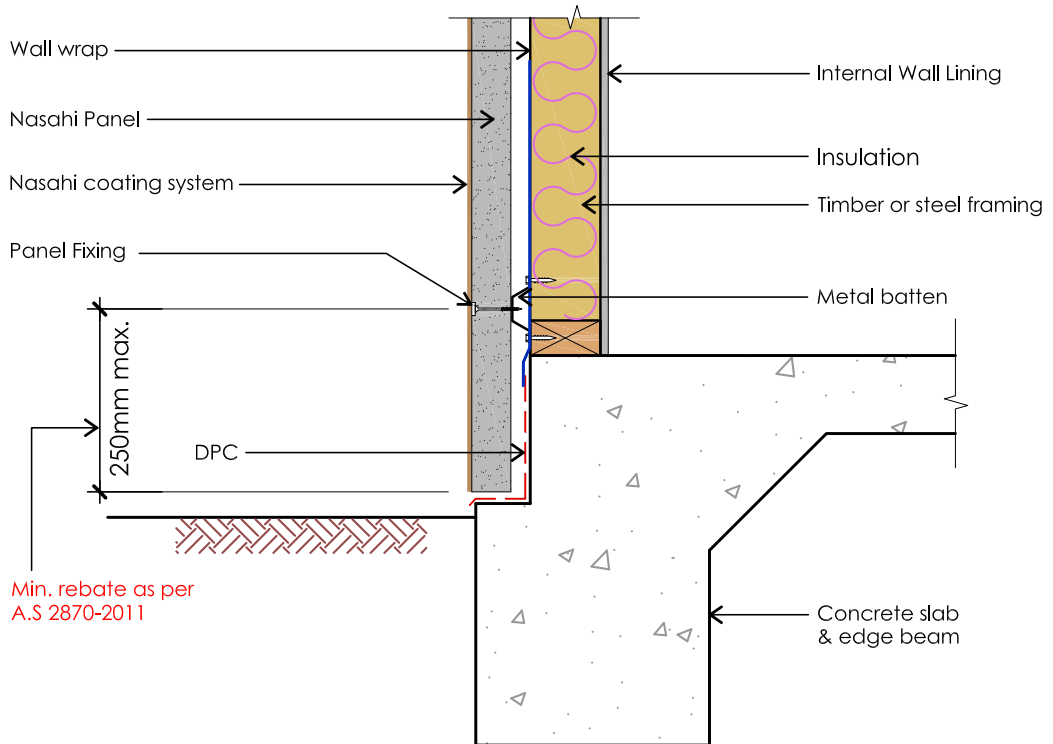

Detail 3.0 Base Panel Detail

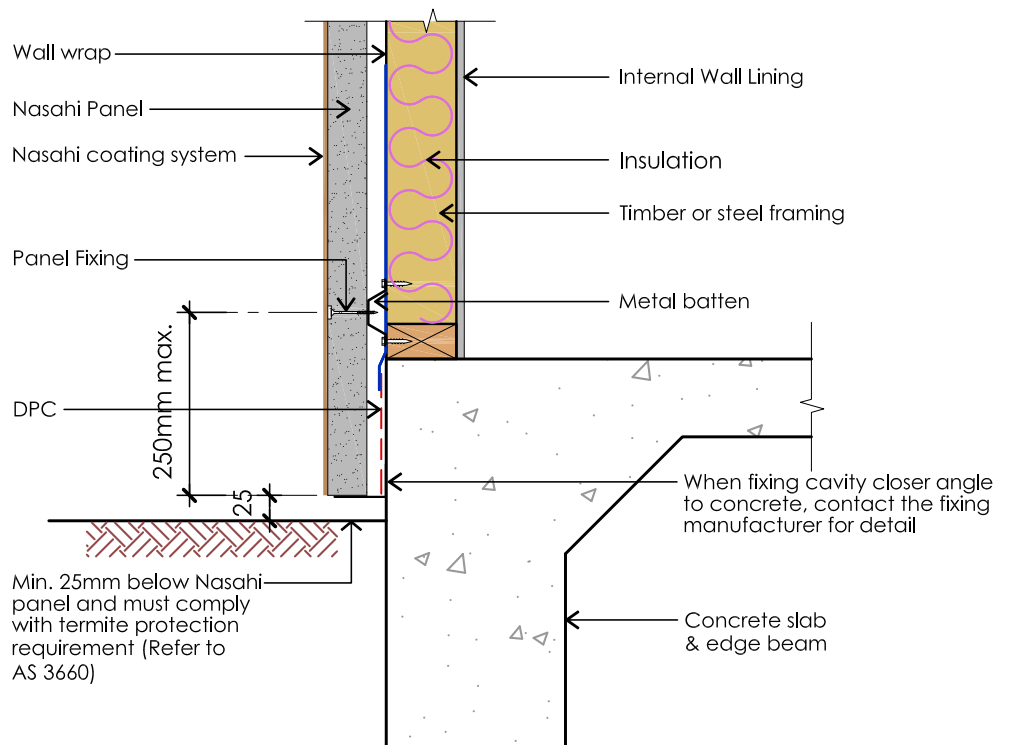

Detail 3.1 Base Panel Detail

# DETAIL DRAWINGS

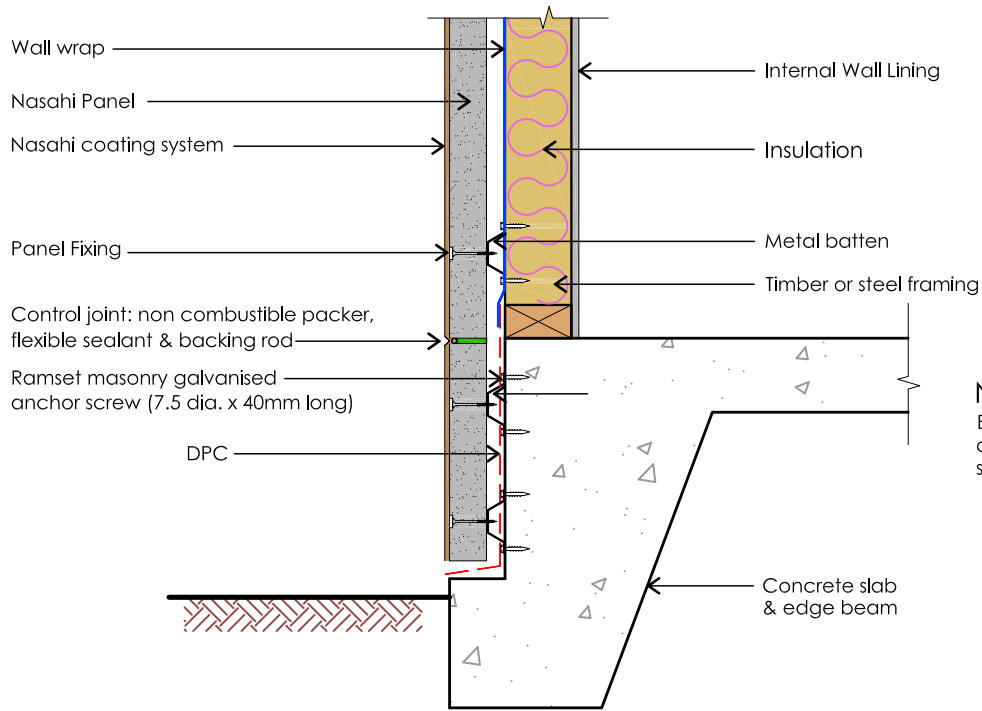

**NOTE:**  
Ensure metal batten fixed to concrete slab is continuous & seals off the cavity

Detail 3.2 Base Panel Detail

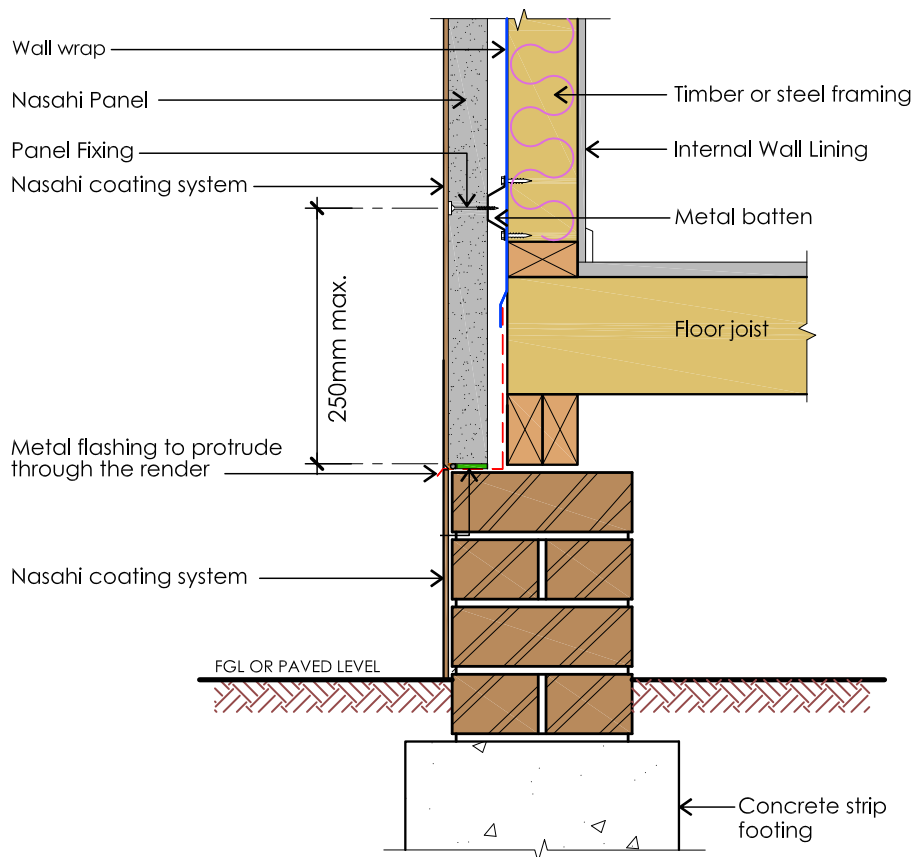

**NOTE:**  
Termite protection as per project requirements

Detail 3.3 Sub-floor 50mm Panel Detail

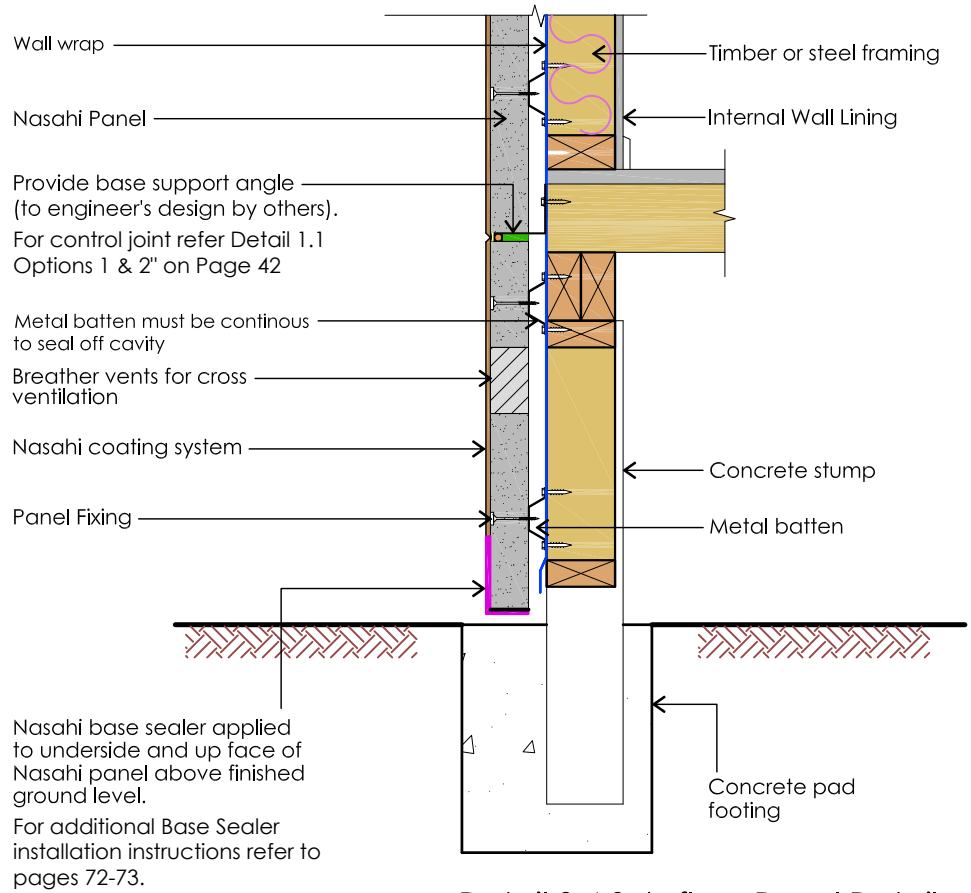

Detail 3.4 Sub-floor Panel Detail

Above finish ground

NOTE:

This slab edge detail does not comply with the termite visible inspection zone requirements. It is the responsibility of the builder to ensure chemical barrier in accordance with AS 3660 is installed or other suitable termite protection system is adopted & to satisfy relevant authority requirements.

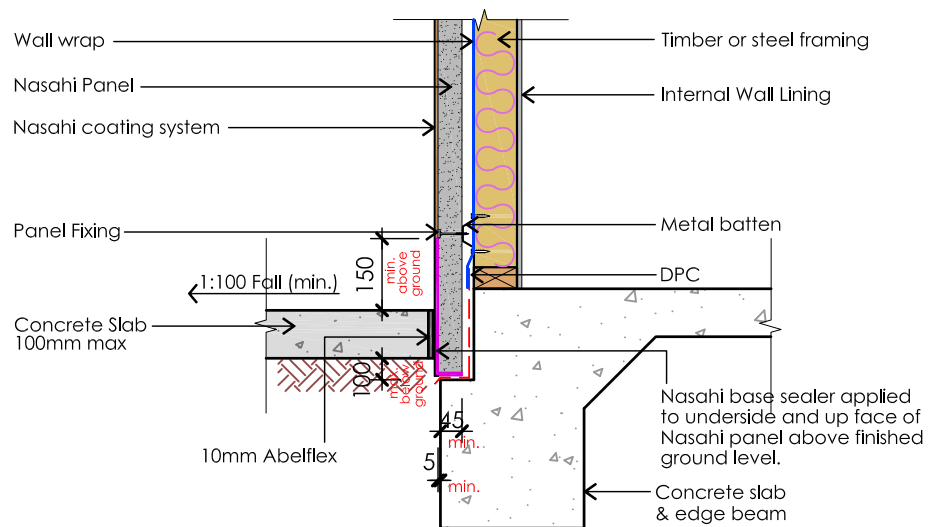

Detail 3.5 Base Panel Detail

Below finish concrete path



# DETAIL DRAWINGS

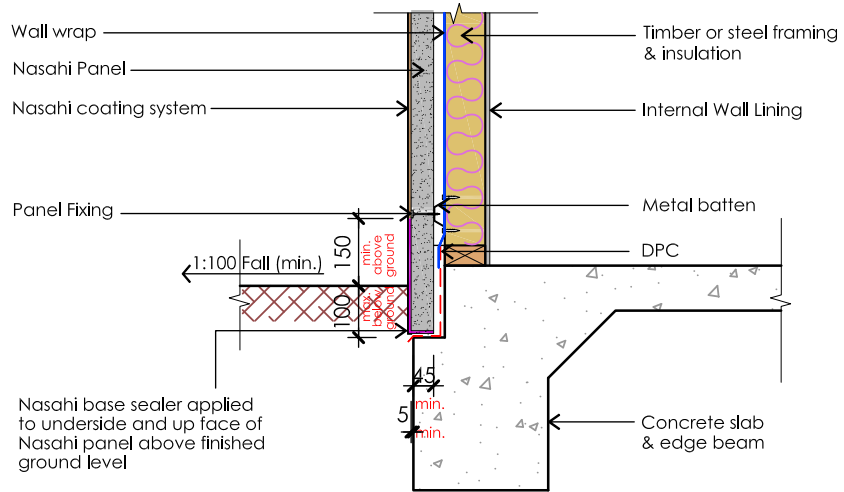

**Detail 3.6 Base Panel Detail**  
Below finish ground

**NOTE:**  
This slab edge detail does not comply with the termite visible inspection zone requirements. It is the responsibility of the builder to ensure chemical barrier in accordance with AS 3660 is installed or other suitable termite protection system is adopted.

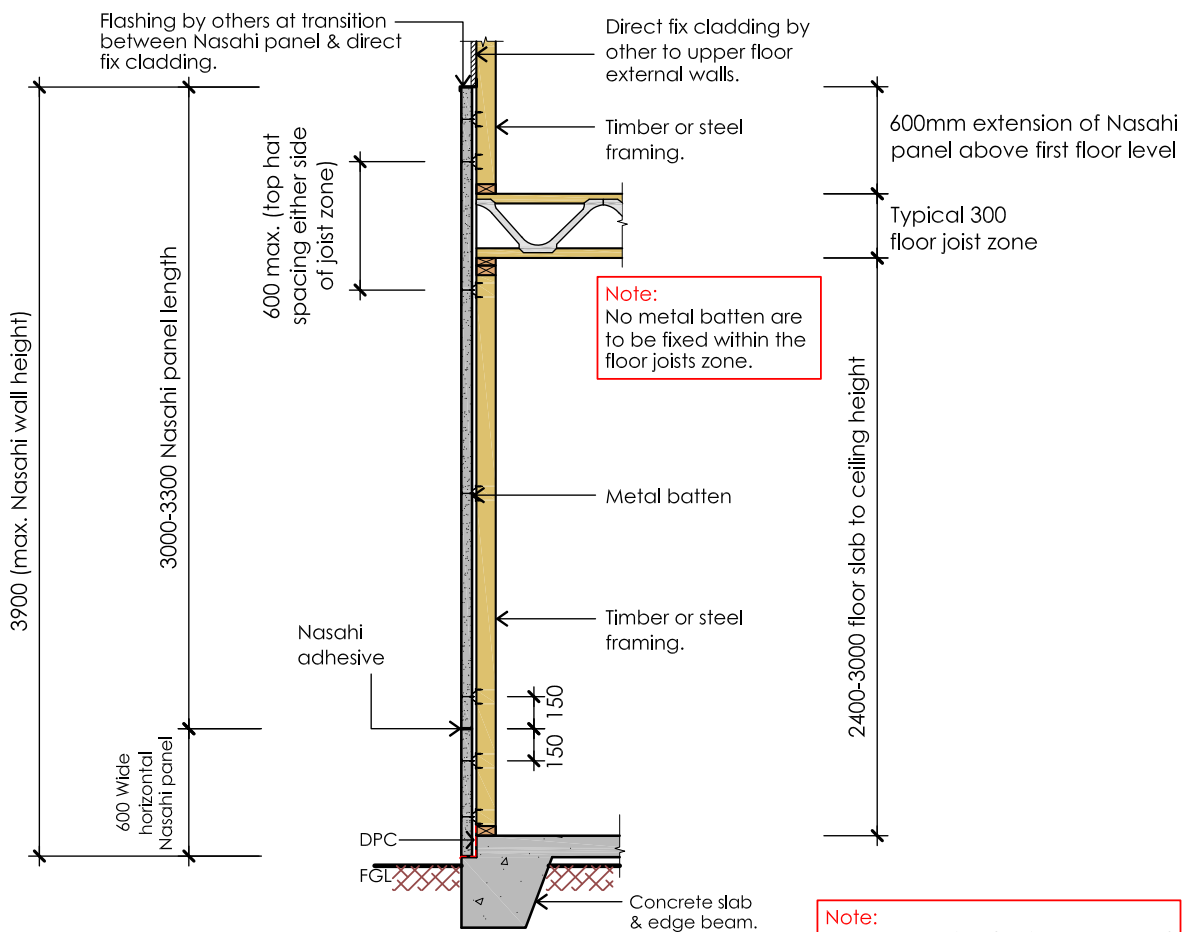

**Detail 3.7 Extending Above First Floor Detail**

**Note:**  
Bottom 600 wide (horizontally panel) can be installed below the vertical panel.

# DETAIL DRAWINGS

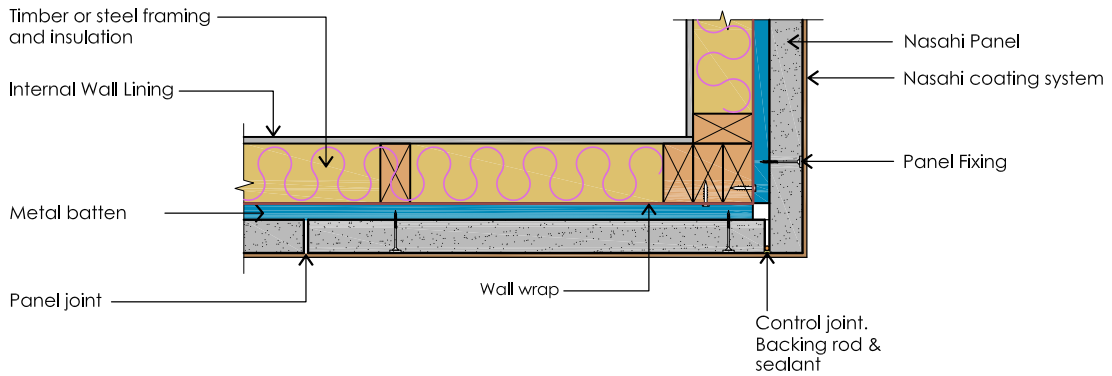

Detail 4.0 External Corner Detail (Option 1)

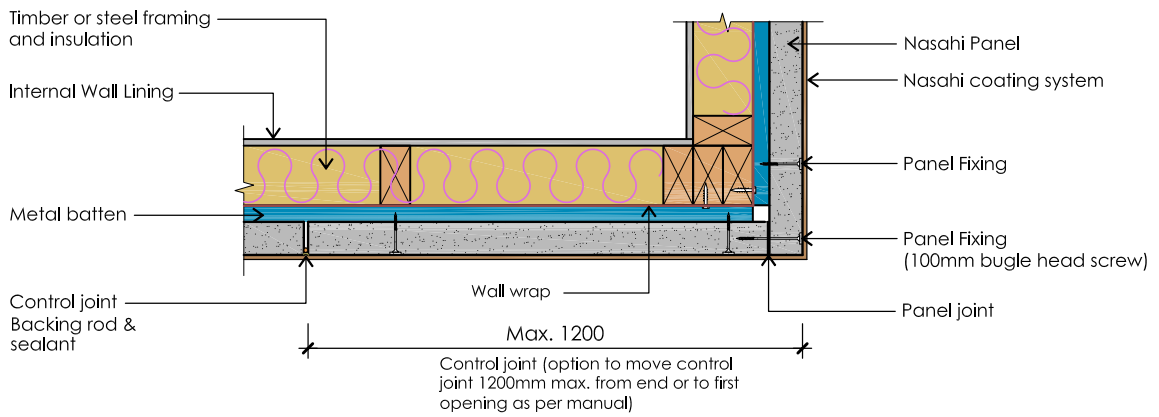

Detail 4.1 External Corner Detail (Option 2)

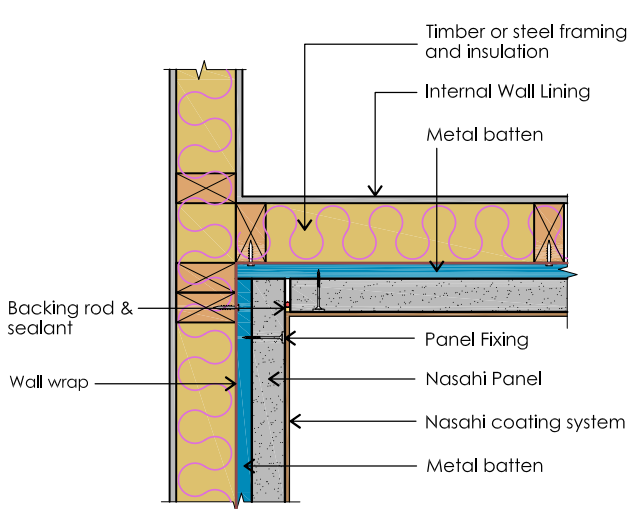

Detail 4.2 Internal Corner Detail

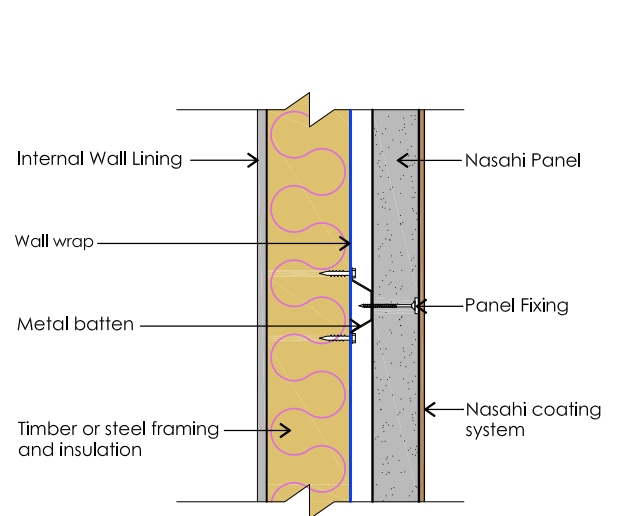

Detail 4.3 External Wall Fixing

# DETAIL DRAWINGS

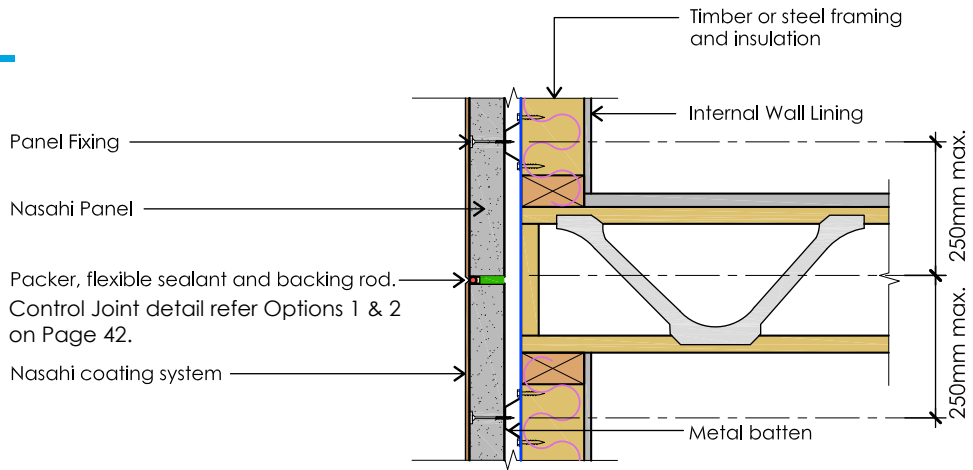

Detail 5.0 Floor Junction Detail (Panel Joint)

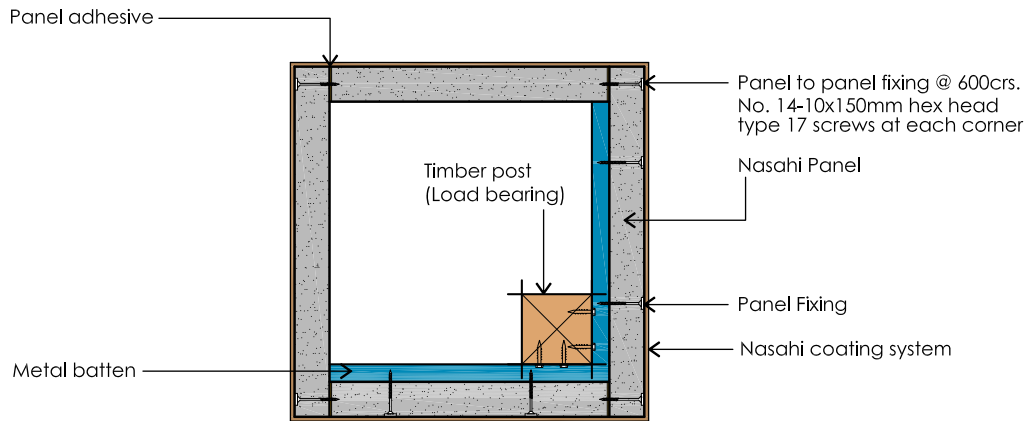

Detail 5.1 Column Detail

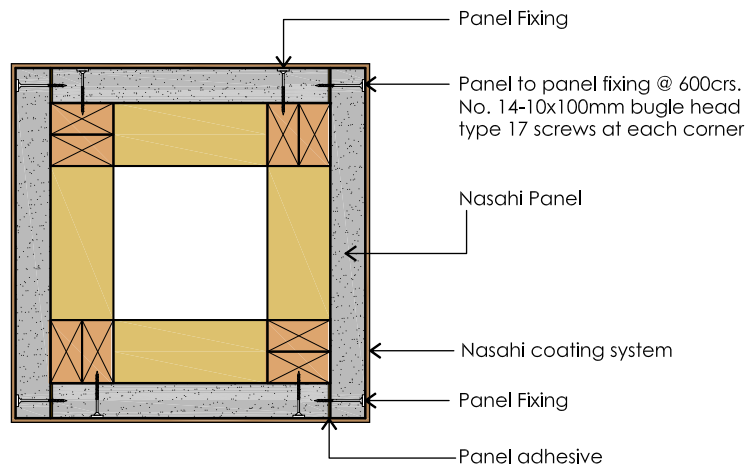

Detail 5.2 Column Detail

# DETAIL DRAWINGS

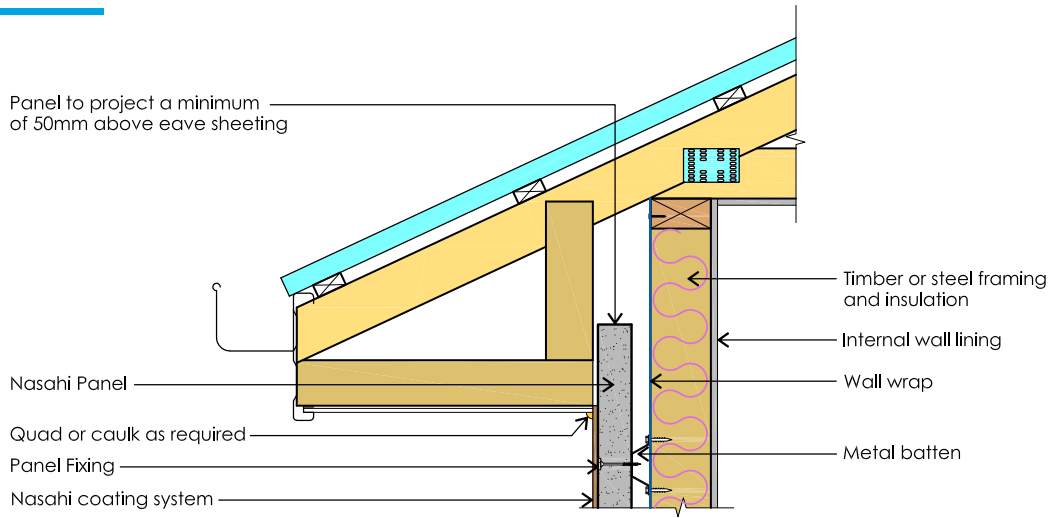

Detail 6.0 Eaves Detail

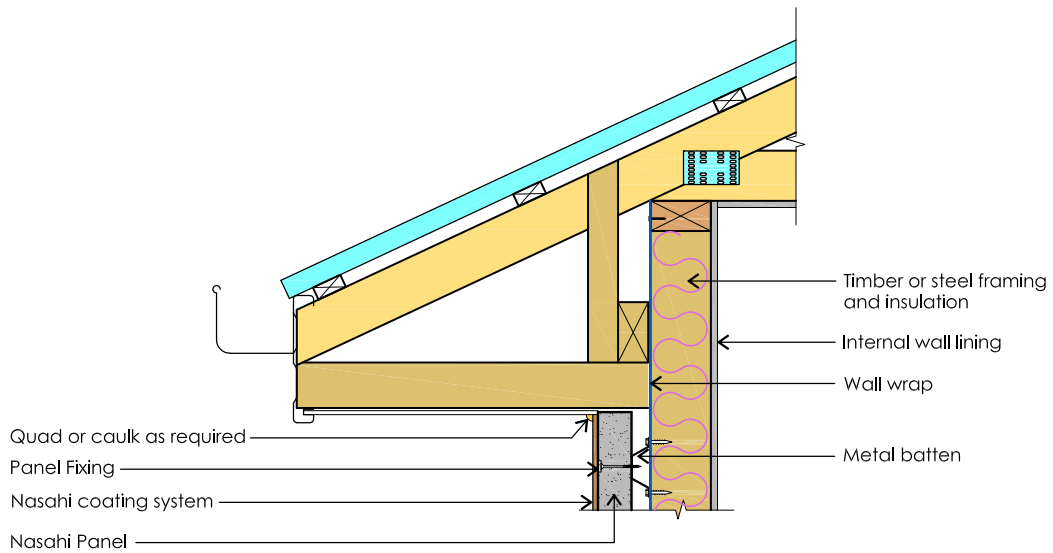

Detail 6.1 Eaves Detail (Panel Under)

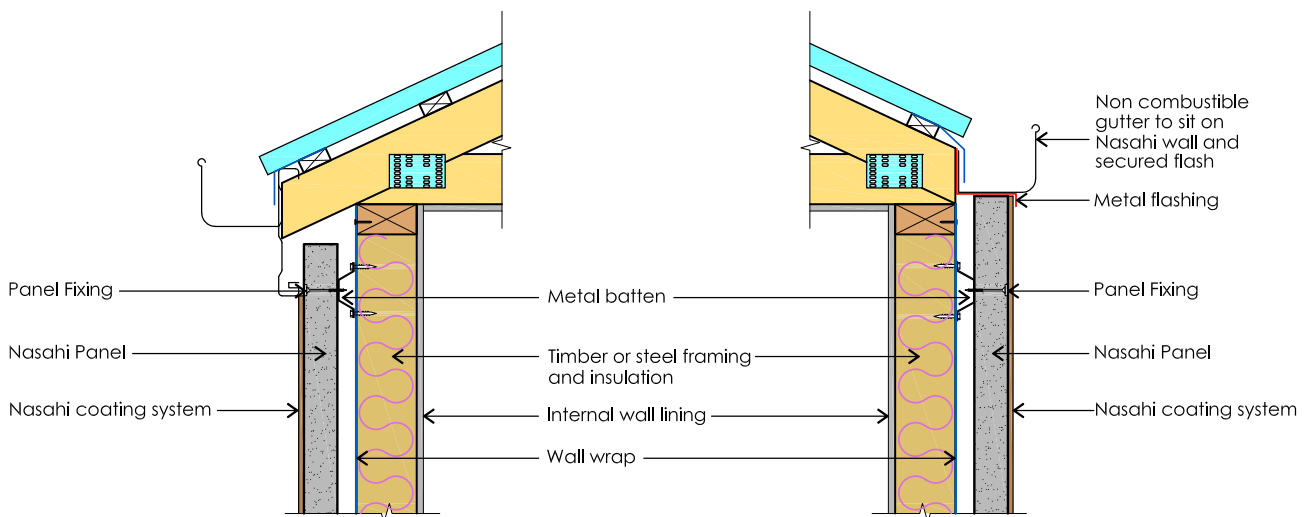

Detail 6.2 Flush Eaves Detail

Detail 6.2.A Gutter On Boundary Wall

DETAIL  
DRAWINGS

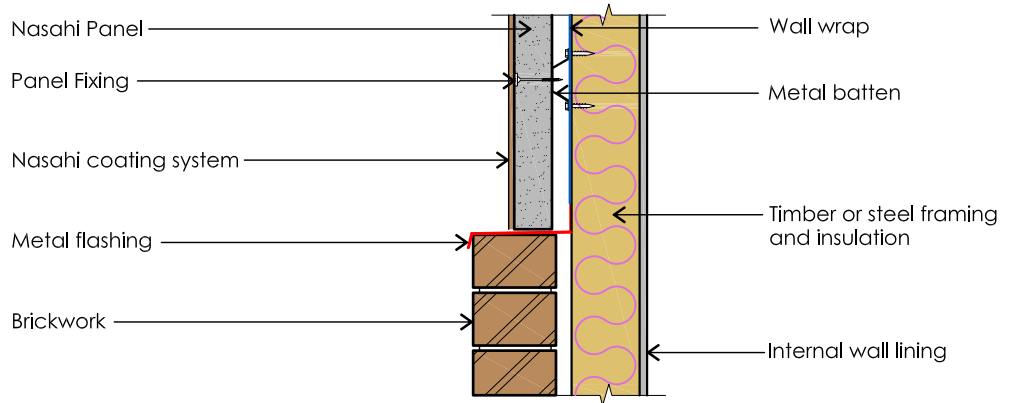

Detail 7.0 Panel to Brick Detail

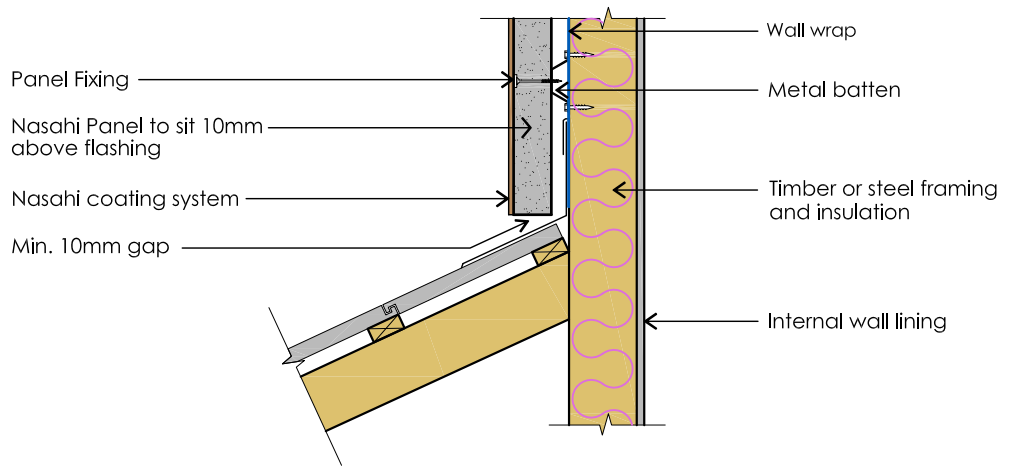

Detail 7.1 Panel to Angle Roof Detail

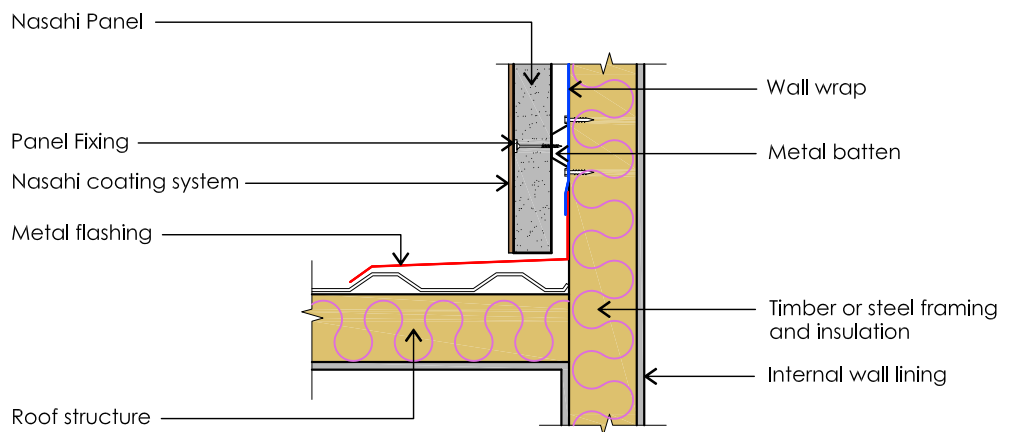

Detail 7.2 Panel to Flat Roof Detail



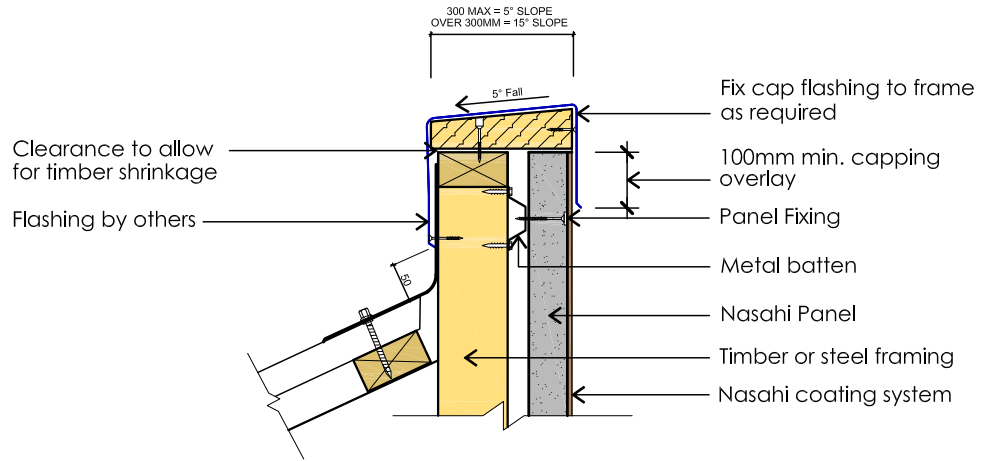

Detail 8.0 Parapet Detail

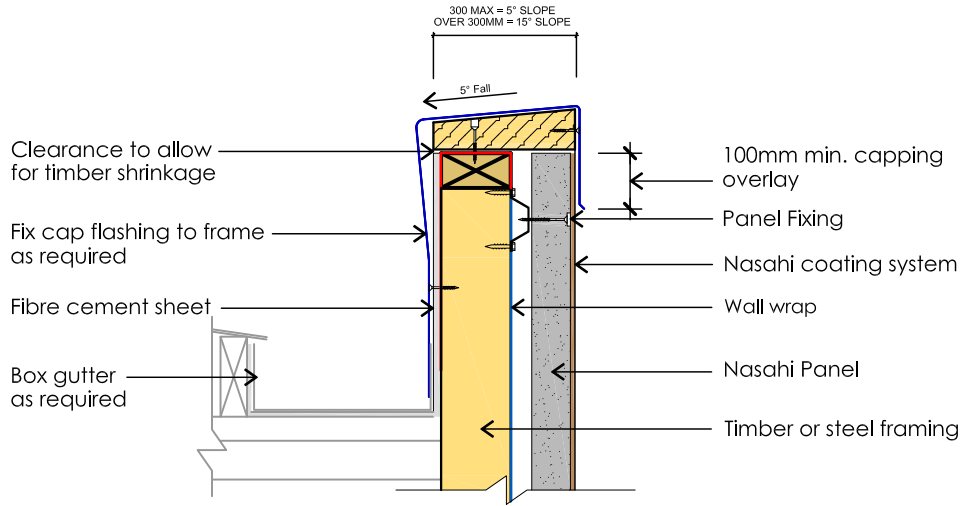

Detail 8.1 Parapet Detail

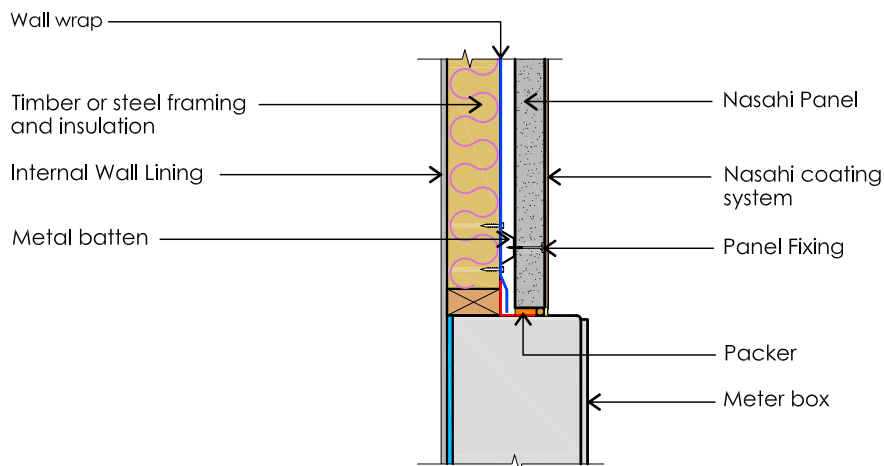

Detail 8.2 Meter Box Installation

# DETAIL DRAWINGS

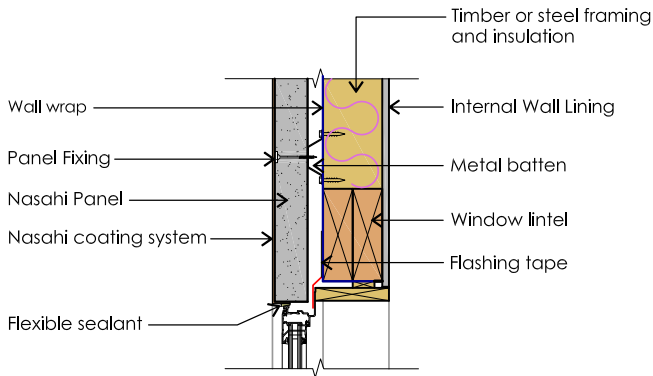

Detail 9.0 Window Head Detail

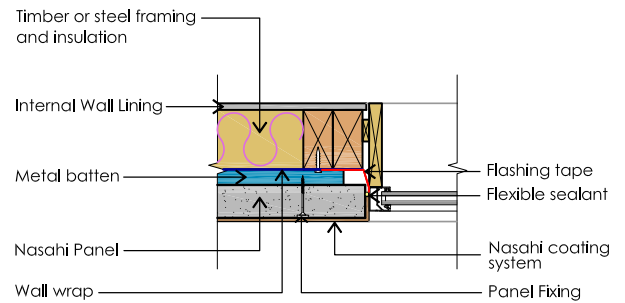

Detail 9.1 Window Jamb Detail

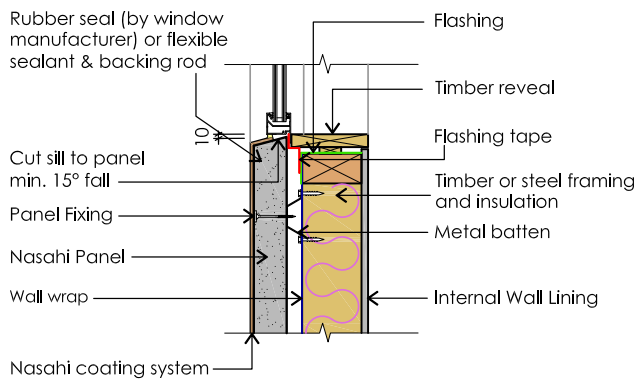

Detail 9.2 Window Sill Detail

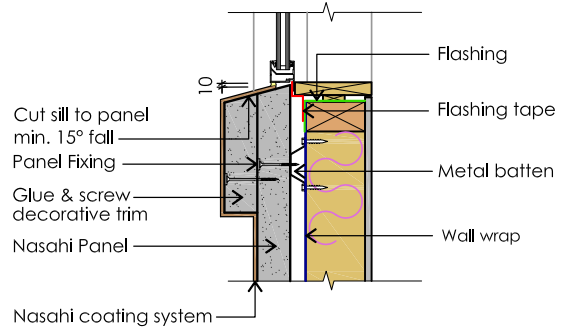

Detail 9.3 Window Sill Detail (Decorative sill)

**Note:**  
Drainage of window and door sills, in either aluminium or timber, should be directed to the outside of the building, on top of the window sill.

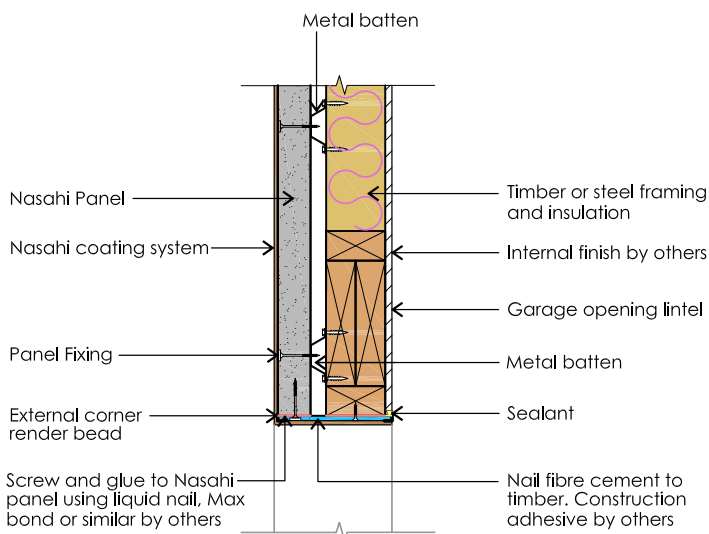

Detail 9.4 Garage Door Head Detail

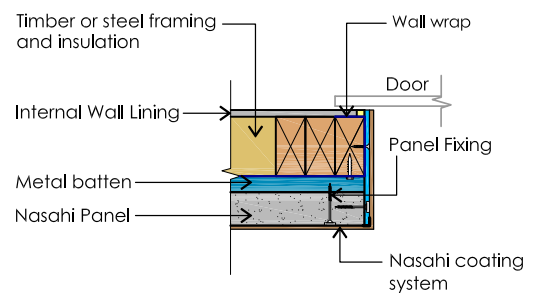

Detail 9.5 Garage Door Jamb Detail

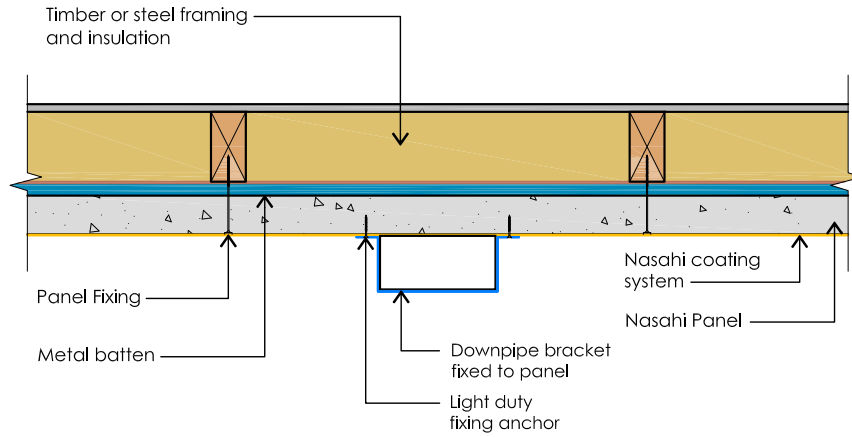

Detail 10.0 External Fixings to Wall

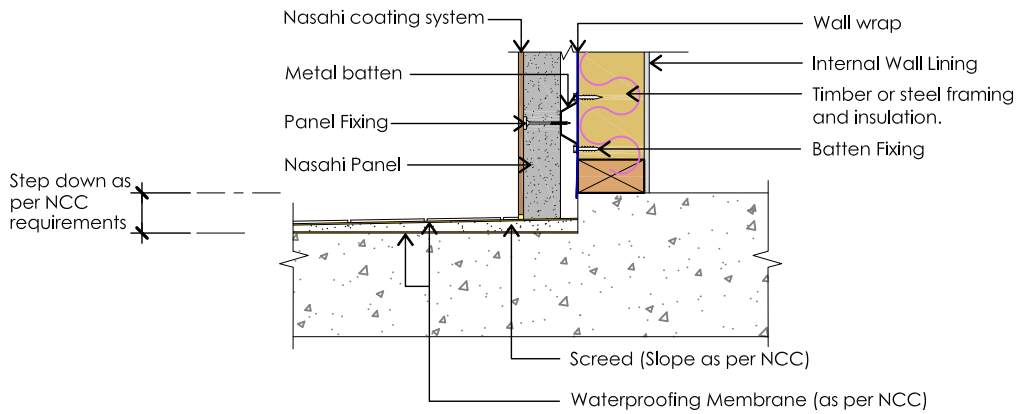

Detail 10.1 Balcony Detail (Concrete slab)

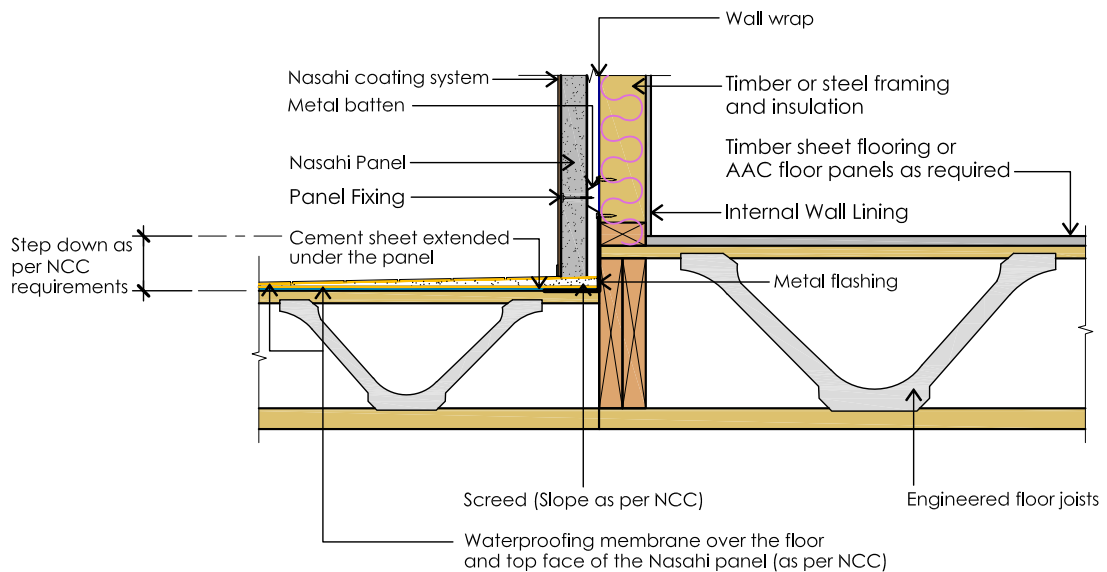

Detail 10.2 Floor Junction Detail  
(Panel Joint in Joist)

**NOTE:**

On balconies if a 2mm gap can not be provided between the bottom of panel and top of tile then weep holes at 1200 centres must be installed.

---

# Low-rise Multi Residential Super<sup>50</sup> Double Walls Zero Boundary System

## DESIGN & INSTALLATION GUIDE

NASAHİ® DOUBLE WALL BOUNDARY SYSTEM HAS BEEN DESIGNED FOR THE NON-LOAD BEARING CONSTRUCTION OF ZERO BOUNDARY ALLOTMENTS.

When a lifting system is used all the frames can be installed first.

The construction is achieved by installing Nasahı® Super50 AAC panels Vertically to the structural timber or steel frame, using Metal Battens (Top Hats or 'C' section) and Direct Fixing Clips.

### SUPER<sup>50</sup> PANEL STANDARD SIZES

50mm x 600mm wide  
x 2400mm, 2550mm  
2700mm, 2850mm and  
3000mm Long.

### SUPER<sup>50</sup> & SUPER<sup>75</sup> SYSTEMS

External Wall Cladding  
System Super<sup>50</sup>

External Wall Cladding  
System Super<sup>75LW</sup>

Party Wall System Super<sup>50</sup>

Party Wall System Super<sup>75LW</sup>

Flooring System

- Fire Rating: FRL 120/120/120 (when subjected to an external fire source)
- Simple proven system
- Separate Tittle construction solution
- Reduced wall thickness

# SYSTEM OVERVIEW

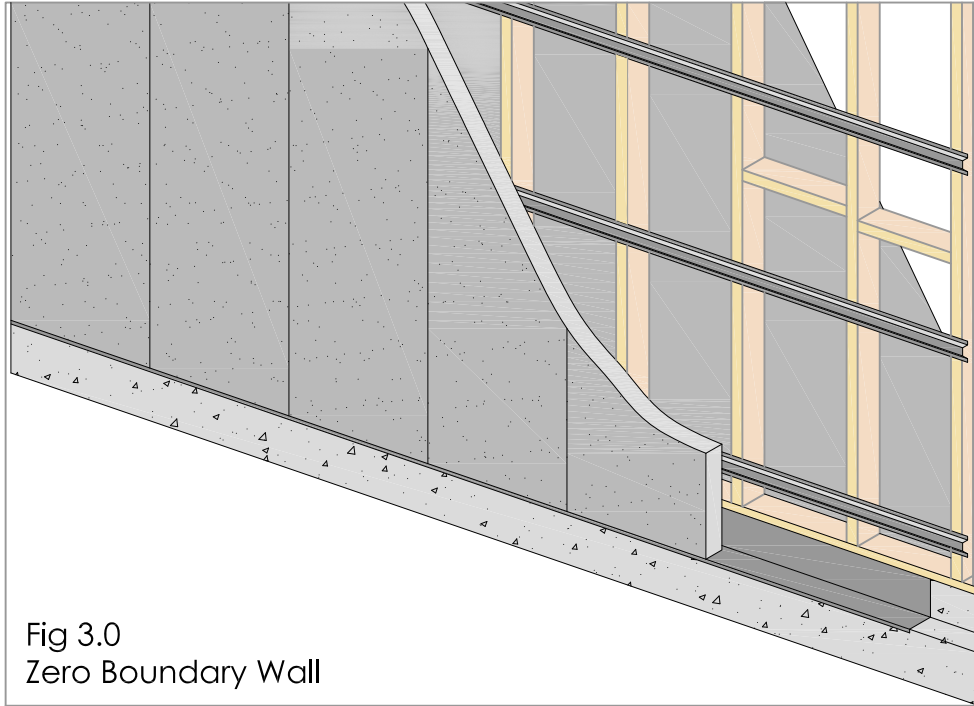
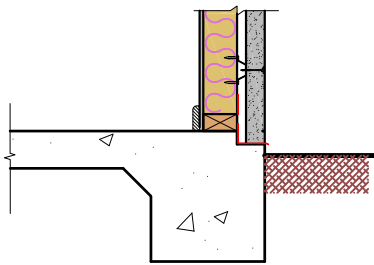
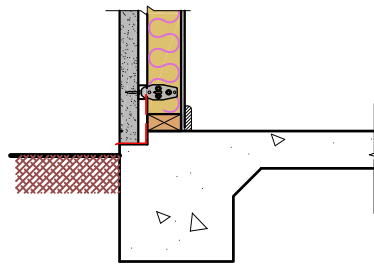

Fig 3.0  
Zero Boundary Wall



Top Hat Batten  
Standard Fixing



Metal Batten  
(Rondo 314 clip)

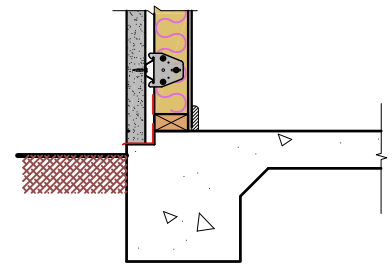

Top Hat Batten  
(Rondo 311D clip)

Table 19

System		Nominal Wall Thickness		Cavity Width (mm)	System Installation	FRL
Stud Width (mm)		Stud Width (mm)				
70	90	70	90			
NA-5016	NA-5016A	111	121	16 Top Hat	16mm Top hat direct fixed to frame	60/60/60
NA-5024	NA-5024A	119	129	24 Top Hat	24mm Top hat direct fixed to frame	
NA-5035	NA-5035A	130	140	35 Top Hat	24mm Top hat direct fixed to frame	
NA-6016	NA-6016A	111	121	16 C-Batten	16mm metal C batten fixed to frame with Rondo 314 clip	60/60/60
NA-6024	NA-6024A	119	129	24 C-Batten	24mm metal C batten fixed to frame with Rondo 314 clip	
NA-7016	NA-7016A	111	121	16 Top Hat	16mm Top hat fixed to frame with Rondo 311D clip	60/60/60
NA-7024	NA-7024A	119	129	24 Top Hat	24mm Top hat fixed to frame with Rondo 311D clip	



## BOUNDARY WALL SYSTEM INSTALLATION SEQUENCE (STAND-UP OR (SLIDE-IN PANEL METHOD)

1. Construct Frame 2 for fixing to Nasahi® Panel: Once the frame is constructed, install 16, 24, or 35mm Steel Galvanised battens as follow: - 150mm down from the top plate and 150mm up from the bottom plate of the frame then at a max. 900mm vertical centres with Rondo 314 or 311D batten clips fixed to studs, Boundary Wall System Components, (shown below).

Ensure there is at least 50mm clearance between external panel face and existing building (minimum 115mm from frame 2 to the face of wall 1).

2. Slide Nasahi® Panels into the wall cavity from one end and fix to battens using the 12g x 45mm Hex head screws. 2 screws per batten, per panel per stud. Ensure 2-3mm Nasahi® adhesive is applied at all joints.

3. Panels are to be installed vertically in the wall cavity as per Fig 6.0 on Page 62.

4. A minimum of 35mm step-down and capping over the completed wall cavity is mandatory as per Detail 11.1 on Page 64.

## BOUNDARY WALL SYSTEM COMPONENTS

Table 19 - System Components

### Panel Fasteners



12-11x45  
Head Type 17  
Screws Class 3

### Metal Batten Top Hat

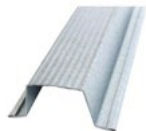

16-24mm Galv.  
Top Hat Batten  
0.48BMT (min) x 3m

### Rondo Batten Clip



311D  
Rondo  
Direct



314 Rondo  
Direct  
Fix Clip

### Batten Fasteners



### Timber Frames

12-11 x 35mm  
Hex Head Type 17  
Class 3 screws

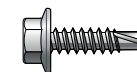

### Steel Frames

10-16 x 20mm  
Hex Head Self-Drilling  
Class 3 Screws

## BOUNDARY WALL SYSTEM (STAND-UP FRAME METHOD)

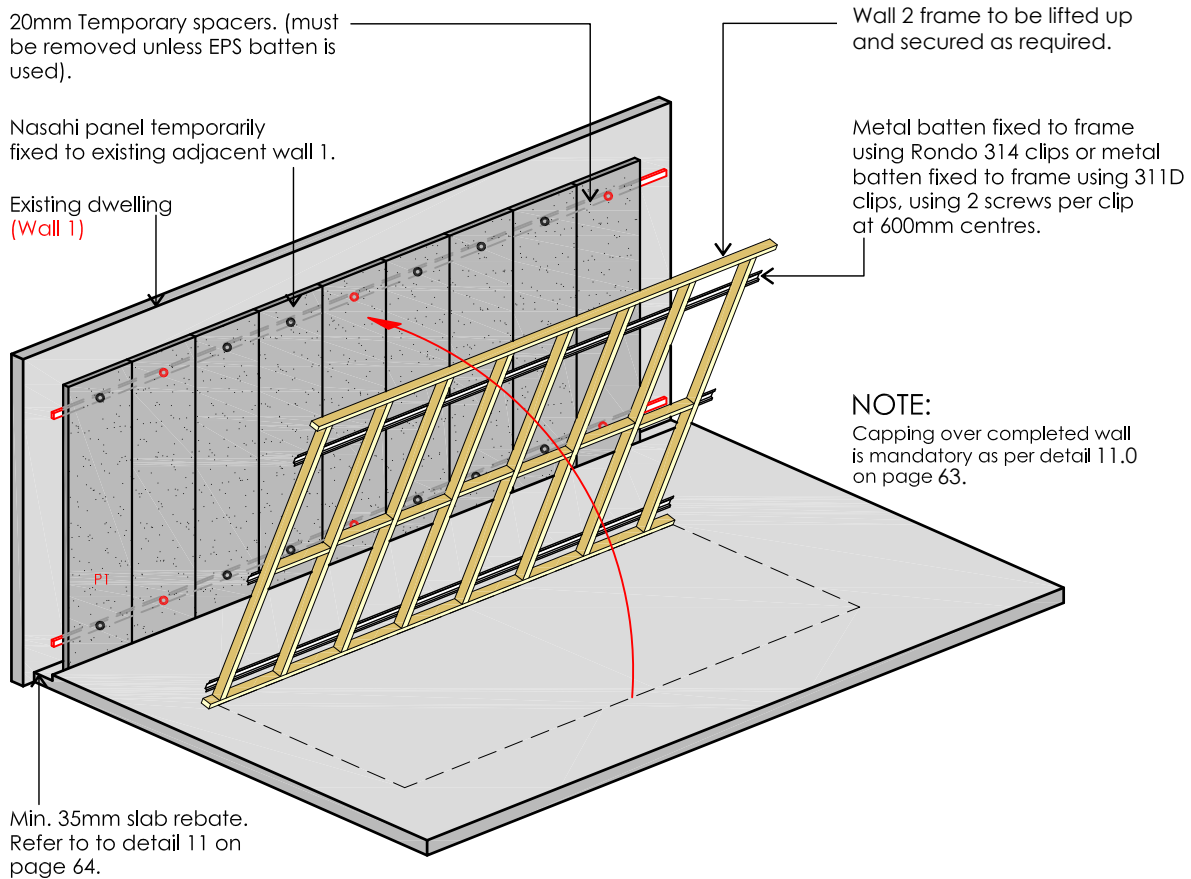

Fig 4.0 Stand-up Frame Method

### WALL 1

Wall 1 is to be installed as per the External Wall Installation Sequence on Page 37-38 and using the External Wall Components on Page 35-36.

### WALL 2

Wall 2 is to be installed as per Boundary Wall Installation Sequence (Stand-up Panel Method) and using the Boundary Wall System components on Page 59.

## BOUNDARY WALL (SLIDE-IN PANEL METHOD)

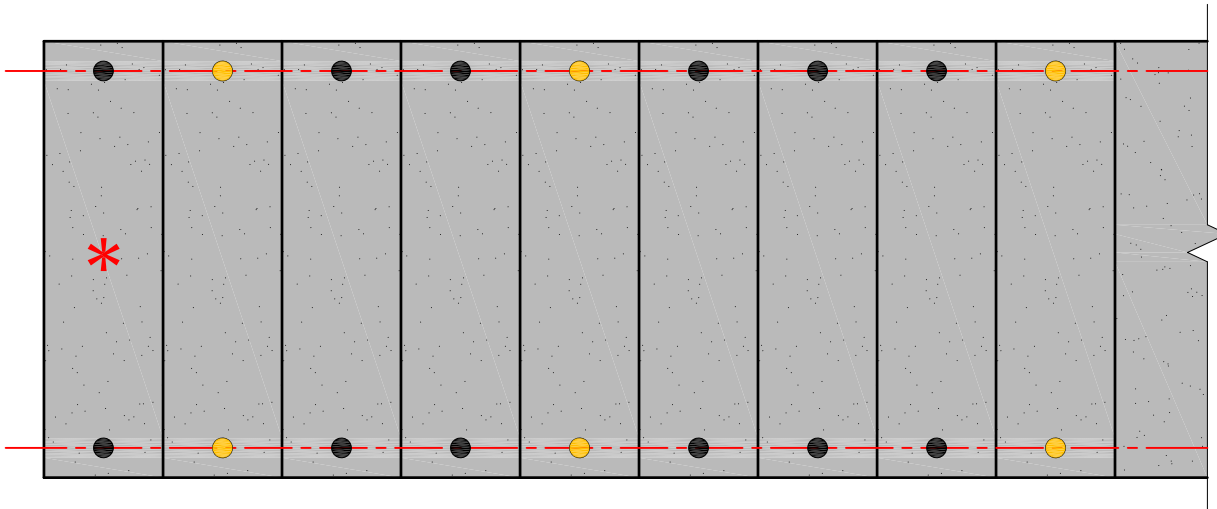

Fig 5.0 Installation Sequence

- — — 20mm Temporary spacer batten or EPS spacer
- Temporary screws
- Panel fixing screws
- \* Starting point for panel install

1. Fix horizontal battens or EPS spacers to existing AAC Wall (Wall 1) with temporary batten screws. ●
2. Commence installing Vertical panels for Wall2 against the batten spacers. Starting at Panel 1 (\*) fix through panel and batten with one screw top and bottom (●) and into Wall 1.
3. When panel 1 (\*) is in place, remove temporary screws (●) at panel 2 location from temporary batten then stand panel 2 and install new temporary top and bottom screws (●) by fixing this panel through spacer and into Wall 1.
4. Continue to install panels in sequential order. Remove any temporary batten screws (●) as you proceed and replace with screw temporary fixing move (●) through newly installed panel.
5. Using the design chart on Page 63, determine the number of battens required and fix these to the face of Wall 2 at locations as noted on design charts.
6. Stand wall frame for Wall 2 and fix the frame to Wall 2 battens using Rondo 314 Batten clips. Typically one Rondo 314 batten clip should be installed at each stud onto each batten location. Studs should be spaced at no greater than 600mm centres.
7. Finally remove previous installed screws (●) from top and bottom of panel and remove temporary battens unless you have used EPS battens.
8. Patch all screw holes with Nasahi Adhesive.

Note: 20mm Temporary spacer batten should be fixed at not greater than 1800 ctrs

# BOUNDARY WALL SYSTEM (SLIDE-IN PANEL METHOD)

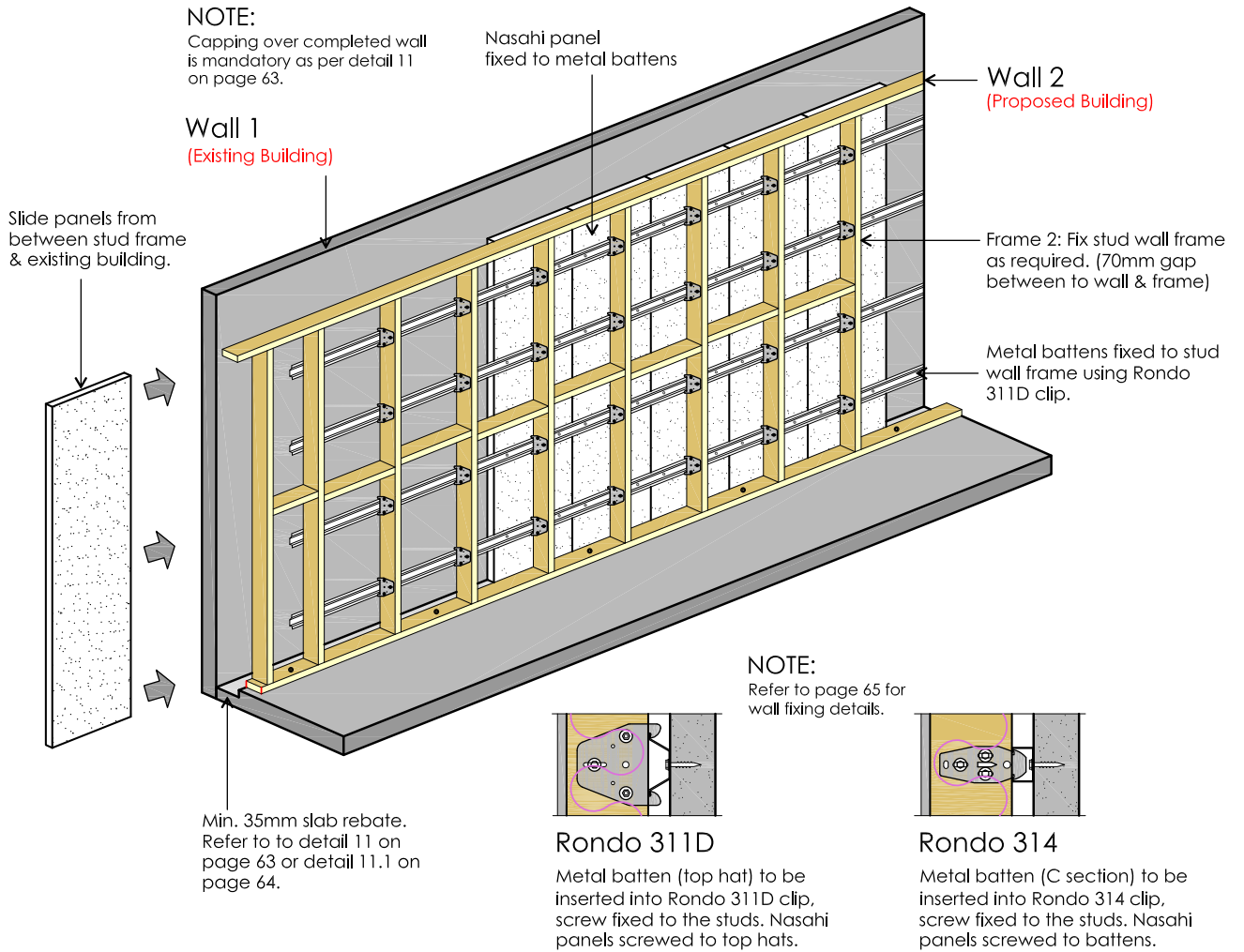
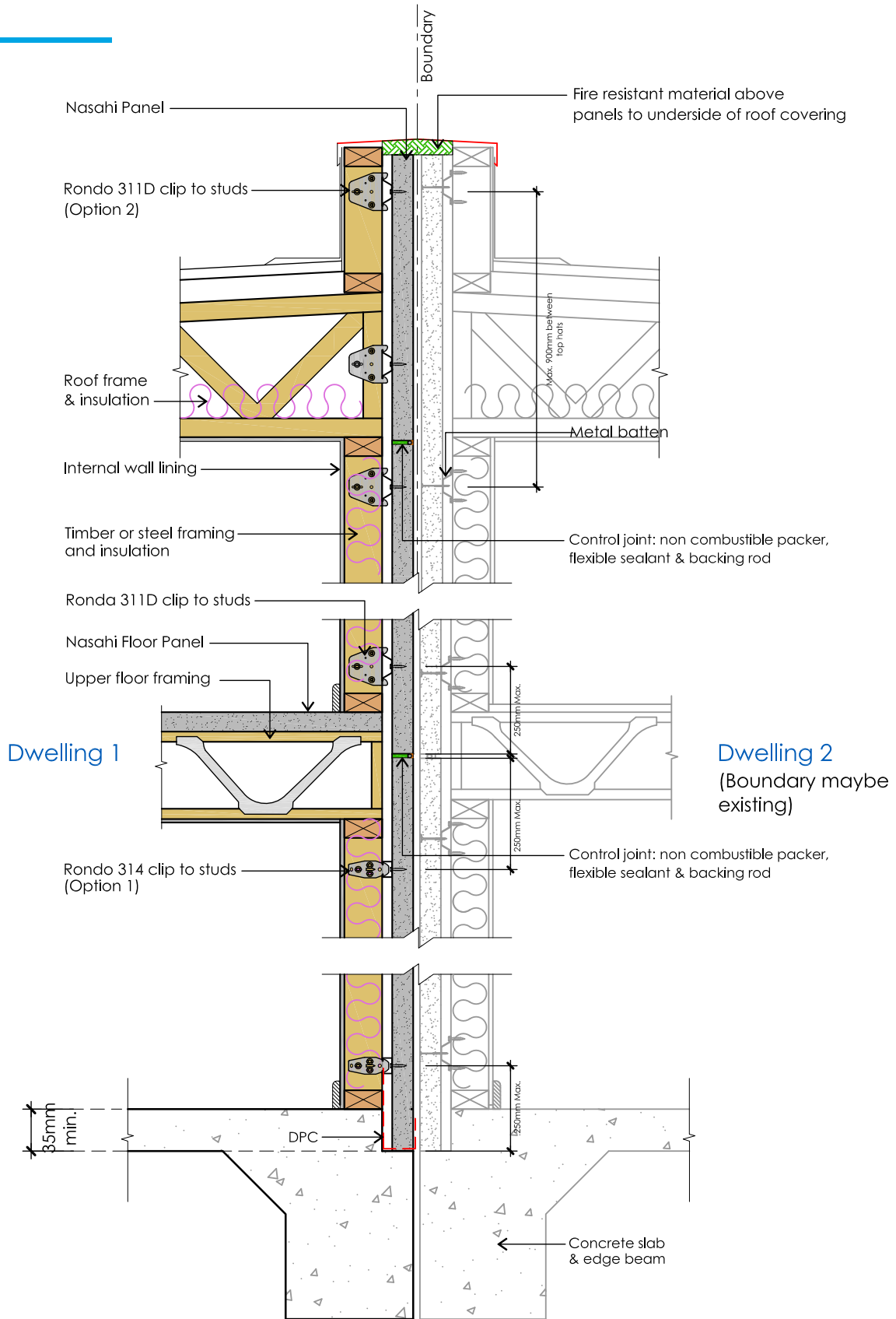

Fig 6.0 Slide-in Panel Method

# DETAILED DRAWINGS



Detail 11.0 External Wall Fixing (Allotment Boundary Wall)



# DETAILED DRAWINGS

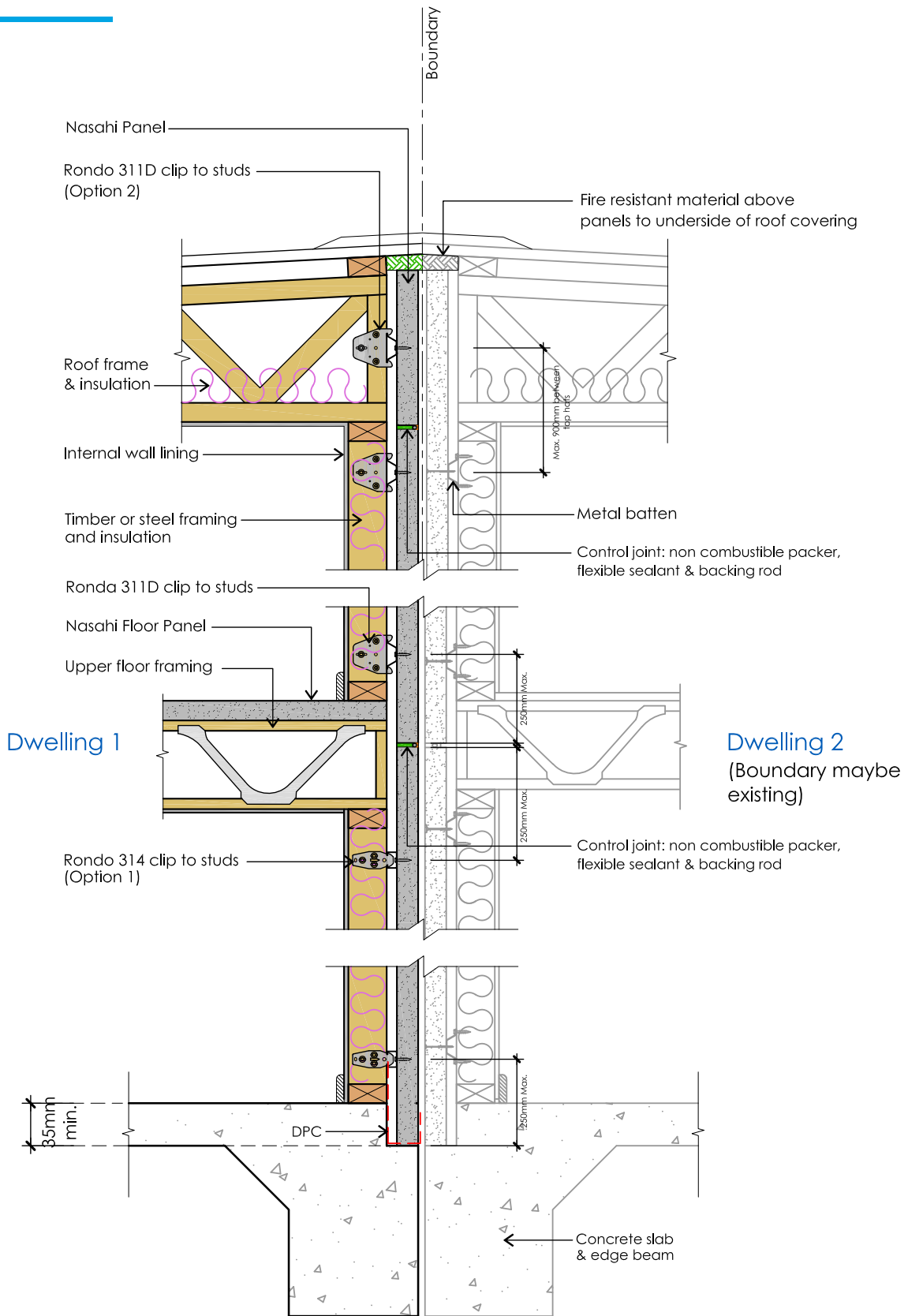

Detail 11.1 External Wall Fixing (Allotment Boundary Wall)

DETAILED DRAWINGS

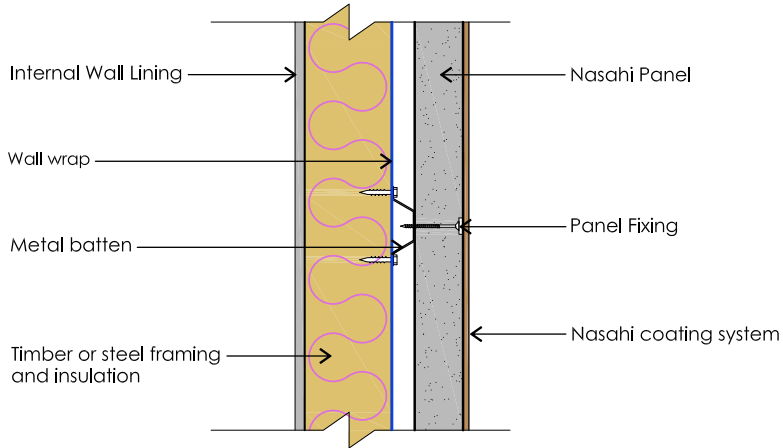

Detail 11.2 External Wall Fixing

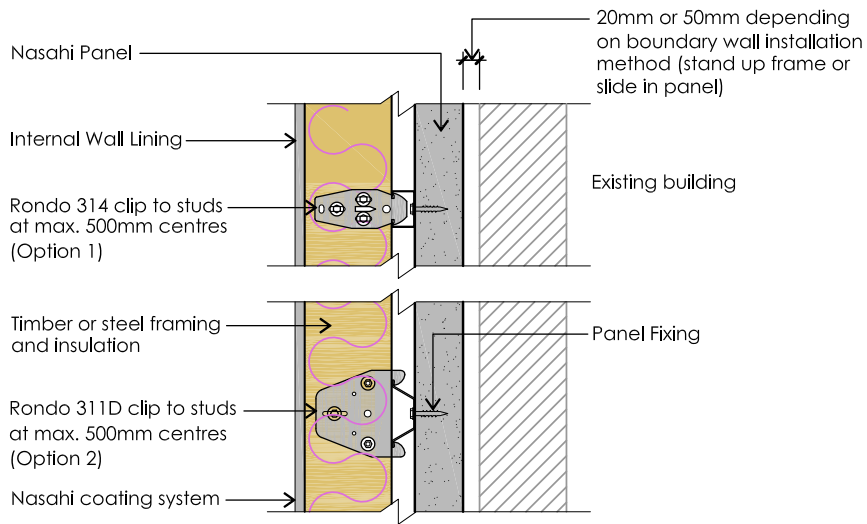

Detail 11.3 External Wall Fixing (Existing building)

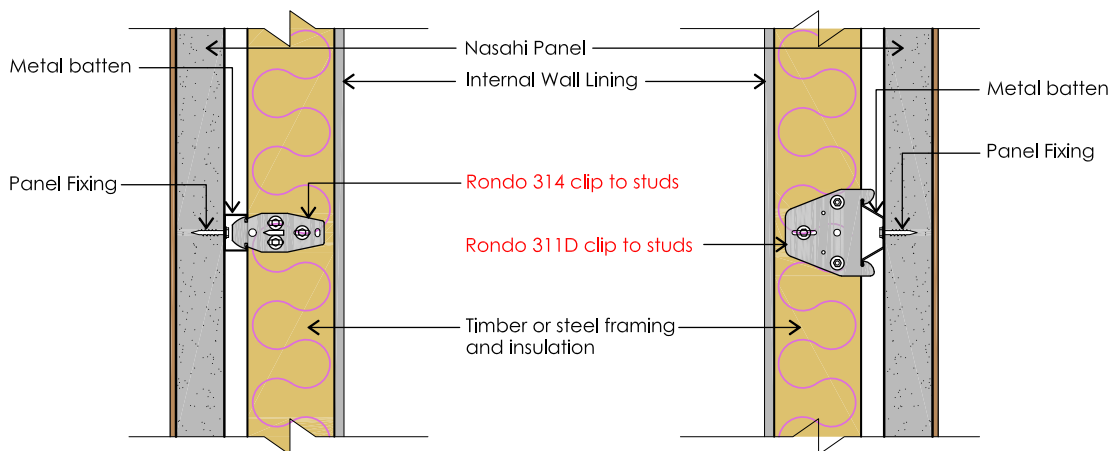

Detail 11.4 External Wall Fixing (Boundary Walls Option 1)

Detail 11.5 Boundary Wall Fixing (Boundary Walls Option 2)

---

# Design Tables for Dual Zero Boundary Walls for Super<sup>50</sup> and Super<sup>75LD</sup> Panels

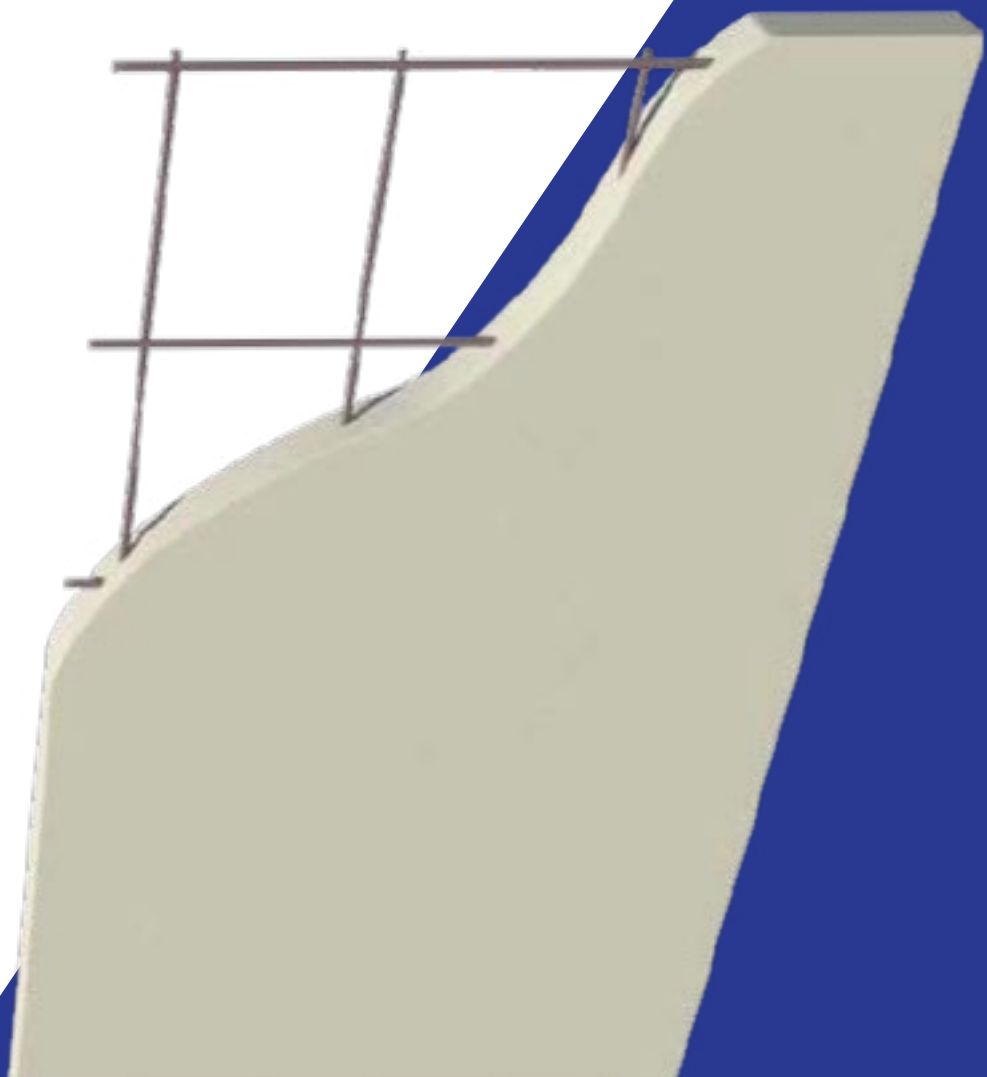

# SUPER<sup>50</sup> DESIGN TABLE FOR BOUNDARY WALLS - BATTENS & SCREWS

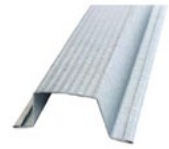

Table 20.0 - No. of Metal Battens (Top Hat) - External Fixing of Panels

TABLE 20.0 - DUAL ZERO BOUNDARY WALLS - NO OF METAL BATTENS (TOP HAT) - EXTERNAL FIXING OF PANELS										50MM PANELS			
VERTICALLY ORIENTED PANELS - BASE SUPPORTED ONLY (MIN 0.42 BMT)													
TEMPORARY DESIGN WIND ASSUMPTION			RECOMMENDED STUD SPACING (MM)		NO. OF TOP HATS REQUIRED								
DURING CONSTRUCTION	GENERAL AREAS ULS WIND PRESSURE (kPA)	CORNER ZONES ULS WIND PRESSURE (kPA)			PANEL LENGTHS (MM)								
					2400		2700		2850		3000		
			GEN	CNR	GEN	CNR	GEN	CNR	GEN	CNR	GEN	CNR	
	-0.74	-1.30	600	600	3	3	3	4	3	4	3	4	

Table 20.1 - No. of Screws - External Fixing of Panels

TABLE 20.1 - DUAL ZERO BOUNDARY WALLS - NO OF SCREWS - EXTERNAL FIXING OF PANELS										50MM PANELS			
TEMPORARY DESIGN WIND ASSUMPTION			RECOMMENDED STUD SPACING (MM)		SCREWS PER TOP HAT / PANEL								
DURING CONSTRUCTION	GENERAL AREAS ULS WIND PRESSURE (kPA)	CORNER ZONES ULS WIND PRESSURE (kPA)			PANEL LENGTHS (MM)								
					2400		2700		2850		3000		
			GEN	CNR	GEN	CNR	GEN	CNR	GEN	CNR	GEN	CNR	
	-0.74	-1.30	600	600	2	2	2	2	2	2	2	2	

Table 20.2 - No. of Metal Battens (Top Hat) - Internal Fixing of Panels

TABLE 20.2 - DUAL ZERO BOUNDARY WALLS - NO OF METAL BATTENS (TOP HAT) - INTERNAL FIXING OF PANELS										50MM PANELS			
VERTICALLY ORIENTED PANELS - BASE SUPPORTED ONLY (MIN 0.42 BMT)													
TEMPORARY DESIGN WIND ASSUMPTION			RECOMMENDED STUD SPACING (MM)		NO. OF TOP HATS REQUIRED								
DURING CONSTRUCTION	INTERNAL WALL ULS WIND PRESSURE kPa				PANEL LENGTHS (MM)								
					2400		2700		2850		3000		
			GEN	CNR	GEN	CNR	GEN	CNR	GEN	CNR	GEN	CNR	
	±0.74		600	600	3	3	3	4	3	4	3	4	

Table 20.3 - No. of Screws - Internal Fixing of Panels

TABLE 20.3 - DUAL ZERO BOUNDARY WALLS - NO OF SCREWS - INTERNAL FIXING OF PANELS										50MM PANELS			
TEMPORARY DESIGN WIND ASSUMPTION			RECOMMENDED STUD SPACING (MM)		SCREWS PER TOP HAT / PANEL								
DURING CONSTRUCTION	INTERNAL WALL ULS WIND PRESSURE kPa				PANEL LENGTHS (MM)								
					2400		2700		2850		3000		
			GEN	CNR	GEN	CNR	GEN	CNR	GEN	CNR	GEN	CNR	
	±0.74		600	600	2	4	2	3	3	3	3	3	

Notes:

1. Negative pressure indicates wind suction
2. Assumed Nasahi® 50mm Panel Dry Density of 525 kg/m<sup>3</sup> and working density of 590 kg/m<sup>3</sup>
3. All top hats to be spaced evenly, with top and bottom top hats installed 100-250mm from the ends of the Nasahi® 50mm AAC Panel
4. Corner panel location applies to all wall cladding and fasteners within 1,200mm of external building corners
5. For fire walls Panels cannot be cantilevered greater than 150mm.
6. A minimum of 2 screws per top hat (per panel) for external fixing
7. minimum of 3 screws per top hat (per panel) for internal fixing (Unless Noted Otherwise)
8. Top Hats shall be secured to Studs using 2 x TEK Screws at each Stud, using the following screws:
  - c. For Timber Studs 12-11 x 35mm Hex Head Type 17 Class 3 screws
  - d. For Steel Studs 10-16 x 20mm Hex Head Self-drilling Class 3 screws
9. Rondo 311D & 314 Direct fix clips to be used where walls are not exposed to external wind loads (dual zero-boundary walls, intertenancy walls etc)
10. Dual Zero Boundary Walls, 1st wall constructed only assumed to be exposed to temporary Wind Loads (refer tables 7.0 to 7.3 if wind exceed those nominated)
11. Panel Screws for External Fixing to Steel Top Hats – 14-10x65mm Bugle Head Type 17 or Hex Head Self-Drilling Class 3 screws
12. Panel Screws for Internal Fixing through Steel Top Hats into AAC – 12-11x45mm Hex Head Type 17 Class 3 screws (Care to be taken to NOT over torque screws)
13. Top Hat battens must be no less than 0.42mm BMT.
14. 1st wall erected expected to have external fixing and 2nd wall expected to be fixed internally

 Reference Clarkson Consulting services Report No:NAS\_24Span\_50\_v2.1 Dated 21 November 2024

# SUPER<sup>75LD</sup> DESIGN TABLE FOR BOUNDARY WALLS - BATTENS & SCREWS

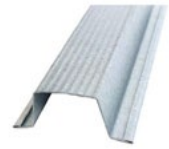

Table 20.4 - No. of Metal Battens (Top Hat) - External Fixing of Panels

TABLE 20.4 - DUAL ZERO BOUNDARY WALLS - NO OF METAL BATTEN (TOP HAT) - EXTERNAL FIXING OF PANELS										75MM PANELS					
VERTICALLY ORIENTED PANELS - BASE SUPPORTED ONLY (MIN 0.42 BMT)															
TEMPORARY DESIGN WIND ASSUMPTION			RECOMMENDED STUD SPACING (MM)		NO. OF TOP HATS REQUIRED										
DURING CONSTRUCTION	GENERAL AREAS ULS WIND PRESSURE (kPA)	CORNER ZONES ULS WIND PRESSURE (kPA)			PANEL LENGTHS (MM)										
					2400		2700		2850		3000		3300		
			GEN	CNR	GEN	CNR	GEN	CNR	GEN	CNR	GEN	CNR	GEN	CNR	
	-0.74	-1.30	600	600	3	4	3	4	3	4	3	4	4	4	

Table 20.5 - No. of Screws - External Fixing of Panels

TABLE 20.5 - DUAL ZERO BOUNDARY WALLS - NO OF SCREWS - EXTERNAL FIXING OF PANELS										75MM PANELS					
TEMPORARY DESIGN WIND ASSUMPTION			RECOMMENDED STUD SPACING (MM)		SCREWS PER TOP HAT / PANEL										
DURING CONSTRUCTION	GENERAL AREAS ULS WIND PRESSURE (kPA)	CORNER ZONES ULS WIND PRESSURE (kPA)			PANEL LENGTHS (MM)										
					2400		2700		2850		3000		3300		
			GEN	CNR	GEN	CNR	GEN	CNR	GEN	CNR	GEN	CNR	GEN	CNR	
	-0.74	-1.30	600	600	2	2	2	2	2	2	2	2	2	2	

Table 20.6 - No. of Metal Battens (Top Hat) - Internal Fixing of Panels

TABLE 20.6 - DUAL ZERO BOUNDARY WALLS - NO OF METAL BATTEN (TOP HAT) - INTERNAL FIXING OF PANELS										75MM PANELS					
VERTICALLY ORIENTED PANELS - BASE SUPPORTED ONLY															
AS4055 WIND ZONES	GENERAL AREAS ULS WIND PRESSURE (kPA)	CORNER ZONES ULS WIND PRESSURE (kPA)	RECOMMENDED STUD SPACING (MM)		NO. OF TOP HATS REQUIRED										
					PANEL LENGTHS (MM)										
					2400		2700		2850		3000		3300		
			GEN	CNR	GEN	CNR	GEN	CNR	GEN	CNR	GEN	CNR	GEN	CNR	
N2w	-0.74	-1.30	600	450	3	4	3	4	3	4	3	4	4	4	

Table 20.7 - No. of Screws - Internal Fixing of Panels

TABLE 20.7 - DUAL ZERO BOUNDARY WALLS - NO OF SCREWS INTERNAL FIXING OF PANELS										75MM PANELS					
AS4055 WIND ZONES	GENERAL AREAS ULS WIND PRESSURE (kPA)	CORNER ZONES ULS WIND PRESSURE (kPA)	RECOMMENDED STUD SPACING (MM)		SCREWS PER TOP HAT / PANEL										
					PANEL LENGTHS (MM)										
					2400		2700		2850		3000		3300		
			GEN	CNR	GEN	CNR	GEN	CNR	GEN	CNR	GEN	CNR	GEN	CNR	
N2w	-0.74	-1.30	600	450	2	3	2	3	3	3	3	3	2	4	



Notes:

1. Negative pressure indicates wind suction
2. Assumed Nasahi® 75mm (LD) Panel Dry Density of 435 kg/m<sup>3</sup> and working density of 490 kg/m<sup>3</sup>
3. All top hats to be spaced evenly, with top and bottom top hats installed 100-250mm from the ends of the Nasahi® 75mm (LD) AAC Panel
4. Corner panel location applies to all wall cladding and fasteners within 1,200mm of external building corners
5. For fire walls Panels cannot be cantilevered greater than 150mm.
6. A minimum of 2 screws per Metal Batten (Top Hat (per panel) for external fixing
7. A minimum of 3 screws per top hat (per panel) for internal fixing (Unless Noted Otherwise)
8. Top Hats shall be secured to Studs using 2 x TEK Screws at each Stud, using the following screws:
  - a. For Timber Studs 12-11 x 35mm Hex Head Type 17 Class 3 screws
  - b. For Steel Studs 10-16 x 20mm Hex Head Self-drilling Class 3 screws
9. Rondo 311D & 314 Direct fix clips to be used where walls are not exposed to external wind
10. Dual Zero Boundary Walls, 1st wall constructed only assumed to be exposed to temporary Wind Loads (refer relevant tables if wind loads exceed those nominated)
11. Panel Screws for External Fixing 75mm AAC to Steel Top Hats – 14-10x95mm Bugle Head Type 17 or Hex Head Self-Drilling Class 3 screws
12. Panel Screws for Internal Fixing through Steel Top Hats into 75mm AAC – 12-11x65mm Hex Head Type 17 Class 3 screws (Care to be taken to NOT over torque screws)
13. Metal Battens (Top Hats) must be no less than 0.42mm BMT.
14. 1st wall erected expected to have external fixing and 2nd wall expected to be fixed internally

 Reference Document: Clarkson Consulting services Report No:NAS\_24Span\_75\_v1.1 Dated 21 November 2024

---

# Base Sealer Application for Super<sup>50</sup> and Super<sup>75LD</sup>

## BASE SEALER APPLICATION

PROCEDURE FOR TREATING THE BASE OF EXTERNAL NASAHI® AAC WALLS WHICH ARE FINISHED A MAXIMUM OF 100MM BELOW FGL AND OR A CONCRETE PATH IS INSTALLED ADJACENT TO AND ABOVE THE FINISHED BASE OF WALL PANEL.

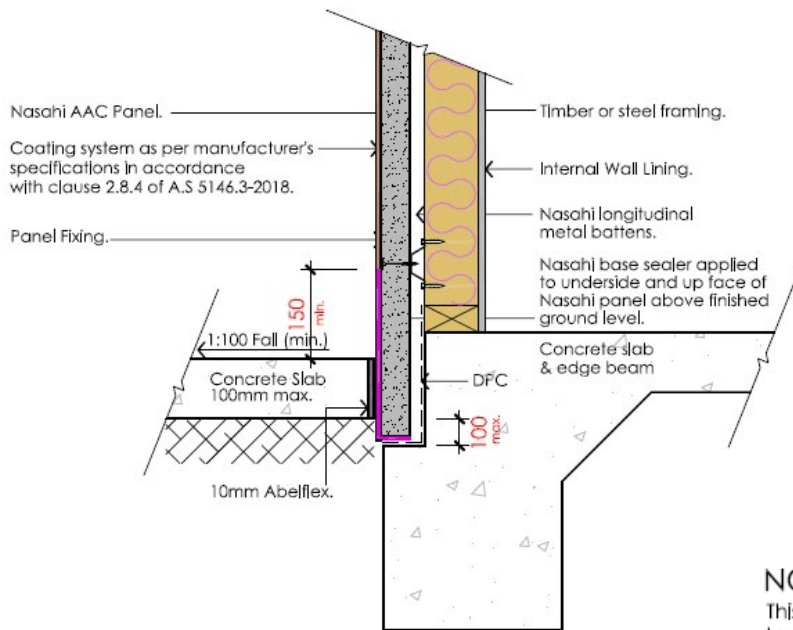

**Base Panel Detail**  
Below finish concrete path

### NOTE:

This slab edge detail does not comply with the termite visible inspection zone requirements. It is the responsibility of the builder to ensure chemical barrier in accordance with A.S.3660 is installed or other suitable termite protection system is adopted.

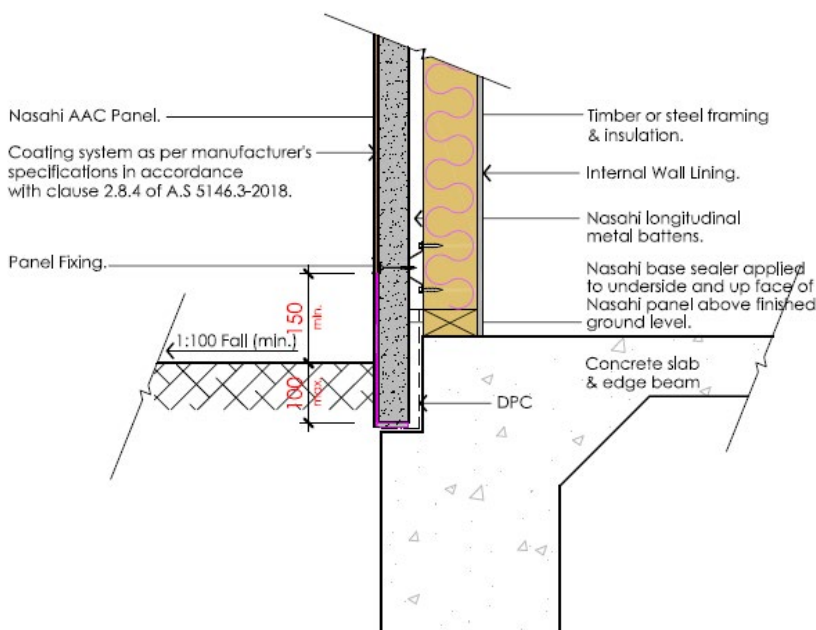

**Base Panel Detail**  
Below finish ground

This procedure must be followed when the base of the Nasahi® Panel has been nominated for install as referenced in the above details by the builder's specification documentation.

## APPLICATION PROCEDURE

1. Check that the base panel will overhang the slab edge by a min of 5mm
2. Ensure that the DPC is installed as detailed in Nasahi® installation guide.
3. Apply the Nasahi® base sealer (using a brush or 20mm nap roller) to all edges of the panel that will be placed face down onto the slab rebate.
4. Apply base sealer to both vertical edges of these panels to a minimum height of 150mm above the finished ground or concrete path height.
5. Allow sealer to dry prior to installation. (ie Touch dry) This should take approximately 15-30 minutes.
6. It is important to check that no areas have been missed or damaged prior to installation. If any damage occurs, before or during installation the base sealer will need to be reapplied to these areas prior to installation. Cutting of panels, dragging, rotating and knocking of corners and edges can cause damage and lead to these areas not being coated adequately. Re-application of the base sealer in these locations must be addressed to ensure the integrity of the sealer is maintained.
7. Once panels have been installed on the wall, check that all panel joints have been sanded flush and all screw holes have been patched and sanded flush. The base sealer can then be applied to the front external face of the panels. A minimum of 150mm above the finished soil/ conc path height should receive the base sealer application (using a brush or 20mm nap roller) ensuring that the sealer fully overlaps with the sealer previously applied to the panel edges. The sealer must be applied as per specification to the entire perimeter of the building ensuring that the designated areas are fully coated. The base sealer must be fully dry prior to application of any render or paint systems.
8. Carry out a final check of the wall to ensure that all areas have been fully coated prior to applying the render systems to the wall.

### Notes:

1. It may be easier to apply the base sealer to all the panels on edge at once before removing from their pack
2. Always adhere to base sealer specification for application rate.

# Delivery & Handling

## DELIVERY

- Nasahi® Panels are delivered to site stacked on Edge in packs of up to 15 per pack
- Each pack has a wet mass of approximately 1000kg and 1100kg, including packaging, see table 21.0, 21.1
- Panel packs must only be stacked one pack high and must be properly supported on level ground
- If packs are to be placed on any type of structure, always consult the project engineer to verify the structural adequacy of the structure
- Nasahi® Panels should be stored on a level surface and never more than one pack high

## MANUAL HANDLING

To reduce the likelihood of damage, handling of Nasahi® Panels around site should be kept to a minimum. When lifting a panel, always pick it up on its long edge and support the weight by lifting with two people as shown below. Before lifting panels, a manual handling risk assessment must be performed to ensure personal injury risk is minimised. Packs should be unloaded as close as possible to the installation area; however, where this is not possible Nasahi® recommends the use of trolleys and/or other mechanical devices.

Table 21.0 - 50mm Panel Packs and Weight - Density 775kg/m<sup>3</sup>

AL PANELS ARE EDGE PACKED				
PANEL THICKNESS	NO. OF PANELS	PANELS PER PACK	PANEL WEIGHT PER PACK (kg)	APPROX WEIGHT PER PACK (kg)
50mm	2400mm	15	55.80	857
	2550mm		59.29	910
	2700mm		62.78	962
	2850mm		66.26	1014
	3000mm		69.75	1066

Table 21.1 - 75mm Panel Packs and Weight - Density 650kg/m<sup>3</sup>

AL PANELS ARE EDGE PACKED				
PANEL THICKNESS	NO. OF PANELS	PANELS PER PACK	PANEL WEIGHT PER PACK (kg)	APPROX WEIGHT PER PACK (kg)
75mm Square Edge	2400mm	10	70.20	722
	2550mm		74.59	766
	2700mm		78.98	810
	2850mm		83.36	854
	3000mm		87.75	898
	3300mm		96.53	985



DO NOT Carry Nasahi® Panels FLAT



ALWAYS Carry Nasahi® Panels ON EDGE

---

# Health & Safety

## HEALTH AND SAFETY

All quarry products, including bricks, concrete and Nasahi® Panels contain Crystalline Silica, or Silica Dust. Prolonged exposure to Silica Dust without the correct PPE can be harmful and potentially cause skin irritation and life-threatening health hazards such as bronchitis, silicosis and lung cancer.

Silica dust is generated when cutting, drilling or moving the panels.

The site should be cleaned of dust regularly and when using power tools these should be fitted with an efficient, well-maintained dust extraction system.

Nasahi® recommends the use of Class M or H industrial vacuum systems for dust extraction. These vacuums suitably capture the dust and also allow for disposal of the waste in a manner to minimise dust exposure.

Nasahi® Panels do not contain any additives that are known to cause health problems; however, because of the risk of exposure to Silica Dust it is recommended that the correct PPE is worn.

The Nasahi® External Wall System Installer is responsible for informing all employees of these Health and Safety requirements under the Occupational Health and Safety Act.

## PERSONAL PROTECTIVE EQUIPMENT (PPE)

When working with Nasahi® Panels, it is recommended that the following Australian compliant PPE is worn as a minimum:

- P1 or P2 Dust masks
- Protective glasses / goggles
- Ear Plugs / Ear Muffs – Class 5
- Gloves, long sleeve shirt and long pants
- Protective footwear



## HAZARDOUS MATERIALS

For MSDS of all components sold by Nasahi®, please visit our website [www.nasahi.net.au](http://www.nasahi.net.au).



---

# Guarantee

NASAHI® GUARANTEE THE PRODUCTS MANUFACTURED BY US AND THE SYSTEMS DESCRIBED IN NASAHI® LITERATURE FOR 7 YEARS, SUBJECT TO THE TERMS AND CONDITIONS OF THE NASAHI® GUARANTEE WHICH CAN BE FOUND ON OUR WEBSITE. NASAHI® DOES NOT GUARANTEE COMPONENTS, PRODUCTS OR SERVICES, SUCH AS INSTALLATION, SUPPLIED BY OTHERS. NASAHI® RECOMMENDS THAT ONLY PRODUCTS, COMPONENTS AND SYSTEMS RECOMMENDED BY IT BE USED.

Nasahi® Approved Coating Systems used with the Nasahi® External Wall System must be guaranteed by the coating manufacturer and meet the minimum performance requirements specified by Nasahi®. It must have been prepared and installed in accordance with the manufacturers written instructions and technical specifications.

Only projects for which a completed Nasahi® Installation Compliance Certificate has been received will be eligible for the Nasahi® guarantee. Blank certificates are available from our website.

This guarantee applies to the performance of the system for the uses outlined in this Installation guide and excludes liability for consequential damage or losses in connection with defective cladding, other than those imposed by legislation.

## WARRANTY

The Nasahi® Panel, when installed in accordance with this guide, are warranted for a minimum of 15 years (from date of purchase) to be free from any defects subject to the conditions and exclusions set out in the Nasahi® Warranty Document available on our website.

Nasahi® Panels are warranted to not materially degrade, corrode or break down during the Term of this warranty (Nasahi® Warranty Document).

This exceeds the 7-year requirement outlined in the NCC and the relevant Australian Standards.

## DISCLAIMER

The information presented within this Installation guide is provided in good faith and to the best of our knowledge and is accurate at the time of preparation. The provision of this information should not be interpreted as a recommendation to use any of our products in violation of patent rights or in breach of statutes or regulations. Users are advised to make their own determination as to the suitability of this information in relation to their particular project and circumstances. As the information contained within this Installation guide may be applied under conditions beyond our control, no responsibility can be accepted by Nasahi®, or its staff for any losses or damage caused by any person acting or refraining from action as a result of misuse of this information.

AAC Building Products Pty Ltd T/A NASAHI® reserves the right to alter or update inclusive information from time to time without notice.

כחכחכחכח  
כחכחכחכח  
כחכחכחכחכח  
כחכחכחכח  
כחכחכחכחכח  
כחכחכחכח



☎ 1300 2 NASAHI

📍 HEAD OFFICE  
1331 Stud Road  
Rowville VIC 3178

✉ sales@nasahi.net.au

🌐 www.nasahi.net.au

fb @ nasahiAU

 **NASAHI**<sup>®</sup>  
*building smarter*